

# Shared Resource Management Hardware Installation Manual

HP 9000 Computers

HP Part Number 98619-90023



**Hewlett-Packard Company**

3404 East Harmony Road, Fort Collins, Colorado 80525

## NOTICE

The information contained in this document is subject to change without notice.

HEWLETT-PACKARD MAKES NO WARRANTY OF ANY KIND WITH REGARD TO THIS MANUAL, INCLUDING, BUT NOT LIMITED TO, THE IMPLIED WARRANTIES OF MERCHANTABILITY AND FITNESS FOR A PARTICULAR PURPOSE. Hewlett-Packard shall not be liable for errors contained herein or direct, indirect, special, incidental or consequential damages in connection with the furnishing, performance, or use of this material.

## WARRANTY

A copy of the specific warranty terms applicable to your Hewlett-Packard product and replacement parts can be obtained from your local Sales and Service Office.

Copyright © Hewlett-Packard Company 1989

This document contains information which is protected by copyright. All rights are reserved. Reproduction, adaptation, or translation without prior written permission is prohibited, except as allowed under the copyright laws.

### Restricted Rights Legend

Use, duplication or disclosure by the U.S. Government Department of Defense is subject to restrictions as set forth in paragraph (b)(3)(ii) of the Rights in Technical Data and Software clause in FAR 52.227-7013.

Use of this manual and flexible disc(s) or tape cartridge(s) supplied for this pack is restricted to this product only. Additional copies of the programs can be made for security and back-up purposes only. Resale of the programs in their present form or with alterations, is expressly prohibited.

# Printing History

---

New editions of this manual will incorporate all material updated since the previous edition. Update packages may be issued between editions and contain replacement and additional pages to be merged into the manual by the user. Each updated page will be indicated by a revision date at the bottom of the page. A vertical bar in the margin indicates the changes on each page. Note that pages which are rearranged due to changes on a previous page are not considered revised.

The manual printing date and part number indicate its current edition. The printing date changes when a new edition is printed. (Minor corrections and updates which are incorporated at reprint do not cause the date to change.) The manual part number changes when extensive technical changes are incorporated.

December 1989...Edition 1. This manual describes SRM systems of Revision 3.2 and earlier.  
This manual replaces 98619-90021.



# Table of Contents

---

## Chapter 1: Introduction

Manual Organization .....	1
Components of the SRM .....	2
Hardware Terminology .....	3
System Overview .....	5
The Server .....	5
The Peripherals .....	5
The Workstations .....	5
The Network .....	6
Installation Planning .....	8
Equipment Layout .....	8
Assigning Node Addresses .....	9
Site Preparation Checklist .....	11
Network Grounding .....	12

## Chapter 2: Server Installation

Introduction .....	13
Types of SRM Servers .....	13
Server Communication on the SRM Link .....	13
Using the HP 50960A SRM Server .....	14
Handling Interfaces – Some Words of Caution .....	14
Unpacking the HP 50960A .....	15
Checking the Voltage Select Setting .....	16
Factory Settings .....	17
Interface and Memory Configuration Switches .....	18
Extra RAM Memory .....	19
Serial Communications Interfaces .....	23
The Server Interfaces .....	26
Installing the HP 46020A or HP 46021A HP-HIL Keyboard .....	32
Installing the Video Monitors .....	34

## Chapter 3: Peripheral Installation

Introduction .....	39
Mass Storage Devices .....	40
Limitations .....	40
Physical Arrangement of Equipment .....	41
Setting Up Your Mass Storage Device .....	42
Connecting the Mass Storage Device .....	44
Printers and Plotters .....	46
HP-IB Printers .....	46
Physical Arrangement of Equipment .....	47
Setting Up Your HP-IB Printer .....	47
Connecting Your HP-IB Printer to the SRM .....	50

Serial Printers .....	51
Setting Up Your Serial Printer .....	52
Connecting Your Serial Printer to the SRM .....	54
Setting Up Your SRM Plotter .....	55
Connecting Your Plotter to the SRM .....	56
<b>Chapter 4: The Network</b>	
Introduction.....	57
The Coax Network .....	58
Correct and Incorrect Coax Connections .....	58
Connecting Servers to the Coax Network.....	59
Connecting Multiple Servers.....	61
<b>Chapter 5: Workstation Installation</b>	
Introduction .....	63
Handling Interfaces – Some Words of Caution .....	64
Interface Configuration Switches .....	65
Installing Series 200 and Series 300 Workstations .....	66
The Coax Network Connection .....	68
Installing Series 500 Workstations .....	72
The Coax Network Connection .....	75
Installing HP Vectra PC Workstations .....	78
<b>Chapter 6: Maintenance, Service, and Repair</b>	
Network Maintenance .....	79
Service and Repair .....	80
Repair Philosophy .....	80
<b>Appendix A</b>	
Supported Hardware .....	81
SRM Server .....	81
SRM Workstations .....	81
System Software .....	82
SRM Servers .....	82
SRM Workstations .....	82
Power Requirements, Weights, and Clearances .....	82
<b>Appendix B</b>	
Example 1: Simple SRM System Using Coax Network Configuration .....	83
SRM System Components.....	83
Example 1: System Map .....	84
Example 1: Worksheet for Workstations and Servers .....	85
Example 1: Worksheet for Shared Peripherals .....	86
Example 2: Multiple Servers/Multiple Discs Using Coax Network Configuration .....	87
SRM System Components .....	87
Example 2: System Map .....	88
Example 2: Worksheet for Workstations and Servers .....	89
Example 2: Worksheets for Shared Peripherals .....	90

## Appendix C

HP 50961 Resource Management Coax Adapter Theory of Operation .....	93
Line Drivers and Receivers .....	94
Handshaking Between the Coax Adapter and the Resource Management Interface	94
Coax Transceiver .....	95
Coax Access State Machine .....	95
Reset .....	95
HP 50962A SRM Coax Interface Theory of Operation .....	96
The DIO Interface .....	96
The Microprocessor .....	96
The Switches .....	97
The Serial I/O Communications Chip .....	97
The Coax Transceiver and Coax Interface .....	97
The Network Management Control Hardware .....	97

## Appendix D

Instructions for Using the Worksheets .....	99
---	----

## Appendix E

The Multiplexer Network .....	103
Multiplexer Network Configuration .....	103
Network Configuration Differences and Compatibilities .....	105
Example: Multiple Servers/Multiple Networks .....	106
Example: System Map .....	107
Example: Worksheet for Workstations and Servers .....	108
Example: Worksheets for Shared Peripherals .....	109
Example: Worksheets for Shared Peripherals .....	110
Example: Worksheets for Shared Peripherals .....	111
HP 98028A Resource Management Multiplexer Theory of Operation .....	112
Power Supplies and Port Isolation .....	113
Line Drivers and Receivers .....	113
Switching and Control Circuit .....	113
Handshaking Between the Multiplexer and Interfaces .....	114
Analog Circuits .....	115
HP 98629 Resource Management Interface Theory of Operation .....	115
Data Transmission on a Multiplexer Network Configuration .....	116
Data Input .....	116
Interface Operation .....	116
HP 98029A Resource Management Interface Theory of Operation .....	117
HP 97061 Cable .....	119





# Introduction

---

The Hewlett-Packard Shared Resource Management (SRM) system is a computer network that enables users of workstations, personal computers, and desktop computers<sup>1</sup> to share common resources such as disc drives, printers, and plotters. SRM allows multiple-user access to disc files (programs and data) and provides shared output devices such as printers and plotters.

---

## Manual Organization

This manual contains information for installing and configuring the hardware components that make up the SRM system. The manual does NOT help you plan an SRM system, but rather assumes system planning was done before the system was ordered. For more information about planning, refer to the *SRM System Planning Guide*. This manual includes the following information:

**Chapter 1:** SRM overview, terminology, and a review of system planning and site preparation considerations.

**Chapter 2:** unpacking and setting up the SRM server.

**Chapter 3:** configuring and connecting the SRM peripherals.

**Chapter 4:** connecting interfaces and cables.

**Chapter 5:** workstation installation.

**Chapter 6:** SRM repair and service philosophy.

**Appendix A:** technical details and specifications.

**Appendix B:** examples of SRM configurations.

**Appendix C:** theory of operation for the HP 50962A SRM Coax Interface and the HP 50961 Resource Management Coax Adapter.

**Appendix D:** system worksheets.

**Appendix E:** multiplexer network configurations, theory of operation for the HP 98028A Resource Management Multiplexer, HP 98629 Resource Management Interface, HP 98029 Resource Management Interface, and HP 97061 Cables.

---

<sup>1</sup> For a list of supported SRM workstations, see Appendix A.

---

## Components of the SRM

Installation procedures and limited service information are included for the following:

- the HP 50960A server;
- the HP 98256A 256-Kbyte RAM Memory Board;
- the HP 98257A 1Mbyte RAM Memory Board;
- the HP 50962A SRM Coax Interface;
- the HP 98651-66532 Human Interface/HP-IB;
- the HP 98204C and 98546-66571 Composite Video Interfaces;
- the HP 82912A, 82913A, and 35731B Video Monitors;
- the HP 98203A/B Keyboard;
- the HP 46020A or HP 40621A HP-HIL Keyboard;
- the HP 50961 Resource Management Coax Adapter and associated cabling;
- various SRM-supported peripherals, including disc drives, tape drives, printers, and plotters; and
- the HP 9000 Series 200, Series 300, and Series 500 computers as SRM workstations.

Installation and configuration instructions will be brief for assemblies that are shipped with their own installation note.

For installation and configuration instructions for the HP Vectra PC as an SRM workstation, refer to the documentation shipped with the HP Language Processor.

---

## Hardware Terminology

Several hardware terms that may need clarification are used in this manual. They are as follows:

**Coax Adapter:** refers to the HP 50961 Resource Management Coax Adapter. This adapter attaches to an HP 98629 or to an HP 27123A to allow the use of these SRM interfaces on a coax link configuration.

**Coax Interface:** refers to the SRM Coax Interface. This interface is functionally equivalent to the HP 50961 coax adapter and HP 98629 SRM interface combination, also used on a coax link configuration.

**Coax Network:** describes the SRM hardware configuration that uses SRM Coax Interfaces or HP 50961 Resource Management Coax Adapters at the workstation and server locations, and uses coax cabling to connect the server(s) and the workstations in a bus fashion.

**Multiplexer Network:** describes the SRM hardware configuration in which the HP 98028A Resource Management Multiplexer and HP 97061 cables are used to connect workstations and the SRM server.

**Peripherals:** devices, such as tape drives or printers, that are connected to a computer to provide input and output operations.

**Resource Management Interface:** generically describes the interface which is inserted in the back of the server or workstation and allows the server or workstation to communicate via the multiplexer network on the SRM system. This interface is also referred to as the SRM interface.

**Resource Management Server:** the component of the SRM system that manages access to shared resources in the resource management system. Shared peripherals are connected to the server. System configuration and maintenance is done through the server's keyboard and CRT display.

The term "controller" is sometimes used interchangeably with "server" when referring to the SRM.

**Resource Management System:** or SRM system; usually refers to the collection of the SRM server, shared peripherals and workstations connected to the server.

**Shared Peripherals:** peripherals that are connected to the server and are accessed from user workstations via the server.

**Shared Resource Multiplexer:** a switching device that controls message flow between computers, allowing one computer to send information while the others receive. It is usually referred to as a multiplexer or a mux. Each multiplexer (HP 98028A) in the system connects one or more workstation computers (up to four) to one or more servers (up to four).

**SRM:** stands for Shared Resource Management, typically used to refer to the server, its operating system software and its peripherals.

**SRM Coax Interface:** the interface used in servers and workstations which allows them to use the coax network configuration without a coax adapter.

**SRM Interface:** the resource management interface.

**SRM Server:** same as Resource Management server:

**System Resources:** all resources in the system that are accessible to multiple workstations in the SRM system; typically the SRM server, shared file system, and shared peripherals.

**Workstation:** any HP computer that is equipped and configured to interact with SRM system resources while retaining the capabilities of a stand-alone computer.

---

# System Overview

## The Server

The heart of the SRM system is the resource management server which runs special software that manages the data communication links to user workstations. The server also handles all mass storage and I/O activities related to the operation and use of shared system resources. The server is dedicated to resource management activities only and cannot be used simultaneously as a user workstation.

An HP 50960A, HP 9000 Model 220 (9920A), or an HP 9000 Model 226 (9826A) can be used as an SRM server. The HP 50960A has six slots (three for I/O) accessible from its backplane. The Model 220 is slightly larger and contains sixteen slots (eight for I/O), easily accommodating multiple multiplexers. The Model 226 (9826A) provides eight slots (four for I/O) from its backplane. The newer 50960A is the recommended server for new installations. Configurations for the 9920A and the 9826A are no longer available; however, servers based on any of these configurations are still supported.

## The Peripherals

Connected to the SRM server are the shared peripherals, including printers and plotters, and disc drives with tape or removable-media disc backup. The number and kind of shared peripherals are dictated by user requirements. A single SRM server can support up to four disc/tape drives and up to eight printers and plotters, four of which can be plotters. Additional peripherals can be connected to individual workstations for special needs, but they cannot be shared by other workstations.

## The Workstations

A workstation is any computer properly equipped to communicate with the SRM system<sup>1</sup>. No workstation can communicate directly with another workstation and information cannot be passed directly from one workstation to another workstation through a server. To pass information from one workstation to a second, the first workstation must place the information in a shared disc file. The second workstation can then access the file to get the information. Aside from accessing the SRM peripherals, the workstations act as independent computers.

---

<sup>1</sup> See Appendix A for a list of supported workstations.

## **The Network**

Communication with the SRM is achieved through either or both of two cabling schemes: the coax network configuration and the multiplexer network configuration. These two configurations are functionally identical and can coexist on the same SRM, provided sufficient I/O slots exist in the server's backplane.

However, the multiplexer network is no longer available, due to the improved distance advantages of the coax network. For more multiplexer network information, turn to Appendix E.

### **Coax Network Configuration**

The coax network configuration uses RG 58C/U coaxial cabling to connect servers and workstations in bus fashion. T connectors link segments of coax cable together at points where servers or workstations are to be connected to the network. Each T connector attaches to either an SRM Coax Interface or to an HP 50961 Resource Management Coax Adapter.

### **Multiplexer Network Configuration**

The multiplexer network configuration uses the HP 98028A Resource Management Multiplexer and HP 97061 cables. Each multiplexer can support up to four workstations. Its fifth port must connect to a dedicated resource management interface in the SRM server.

The following diagram shows a basic SRM configuration.

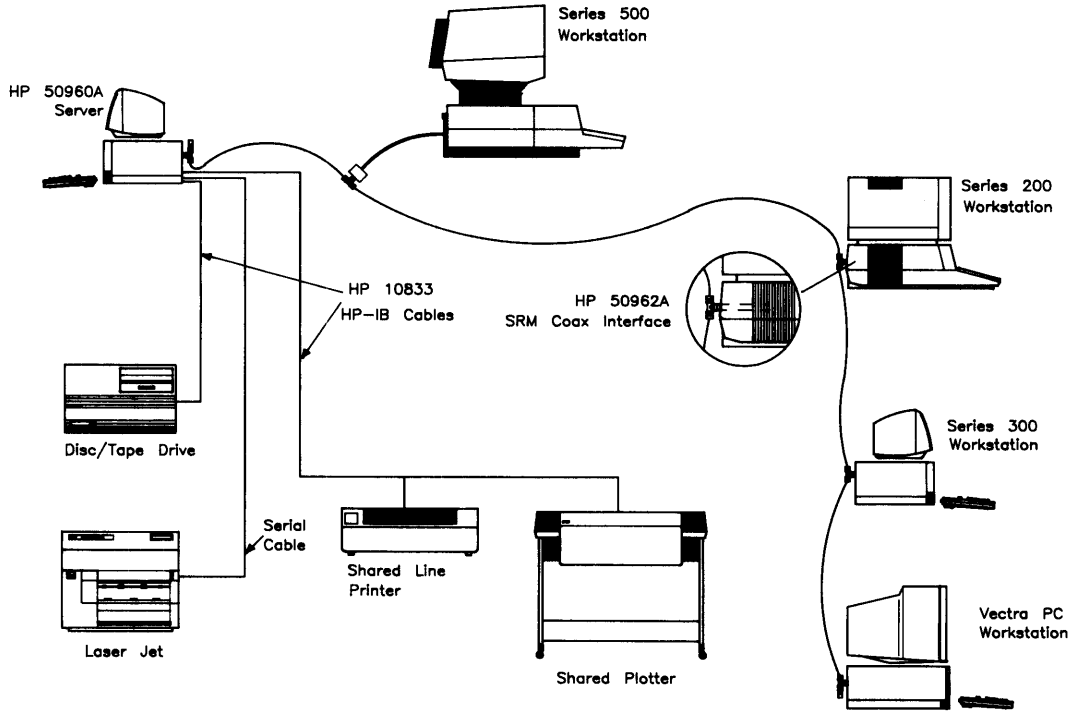

**Example of a Small Resource Management System  
Using the Coax Network**

---

# Installation Planning

## Equipment Layout

When planning the installation of a Shared Resource Management system, it is highly recommended that you make a sketch of the entire area served by the SRM system. You should make the following notes on the sketch for future reference:

- locations of the server and shared peripherals;
- locations of the user workstations;
- user names at those workstations;
- walls, aisles, barriers, or partitions;
- power outlets and exactly which components use them;
- miscellaneous heat, humidity, or electromagnetic noise sources, especially around the server and shared peripherals;
- proximity of workstation users or other personnel to server and shared peripherals;
- logical routes for cables; and
- distances between servers and workstations; between peripherals on the same HP-IB cable; and between workstations.

## Technical Considerations

As the system is laid out, some technical considerations should be taken into account. Consult the SRM planning information you received from your HP representative. If you need additional information, consult equipment installation and operating manuals for your peripherals, or contact your nearest HP Sales and Service office for assistance.

In brief, consideration should be given to the following:

- Is there adequate air flow available to cooling fans and equipment ventilation holes?
- Is there adequate space for servicing the equipment?
- Is the proximity of equipment such that acoustical noise will not become a source of fatigue or irritation?
- Is there adequate ventilation and filtration for the SRM system environment so that heat, humidity, smoke, dust, and chemical vapors will not present a problem to the equipment or its users?
- Can cables be routed, properly supported, and protected to prevent damage to equipment and personnel?



- Can system components be positioned so that electromagnetic interference is not a problem? For example, some HP printers contain large electromagnets that drive the printer mechanics. Placing a printer too close to another printer or too close to a disc drive can degrade the performance of the printers or the disc drive. If possible, allow one metre (three feet) between any system printer and the nearest disc drive.
- Is electrical power sufficient at each power outlet?
- Are power lines adequately conditioned and correctly grounded?

## Assigning Node Addresses

Once you've established the physical layout of the SRM system, you should assign "node addresses" to every workstation and server on the SRM. All communication on the SRM link is routed according to source and destination node addresses combined with interface select codes.

Select codes and node addresses are physically set via switches on the resource management interfaces that plug into each workstation and server. How to set these switches is covered in detail later in the manual.

The worksheets in Appendix D of this manual help you plan and record the addresses and select codes of each computer and peripheral in your SRM system as shown below.

WORKSTATIONS:						CONNECTED TO SERVERS :			
User's Name	User's Phone Number	Workstation		Workstation Select Code	Node Address	HP 98629 Interface Select Code of Server at			
		Location	Type			Node Address 0	Node Address 1	Node Address 2	Node Address 3
George	x 2233	post 7	310	21	10	21			
Sally	x 2312	post 9	310	21	11	21			
Gregg	x 3461	post 4	320	21	12	21			
Bob	x 2158	post 10	310	21	13	21			

In addition, the customer who has ordered an SRM system with an HP 50960A server will receive adhesive-backed node address labels. These labels can be affixed to the SRM interface to note the interface's node address.

## Guidelines

The following guidelines for assigning node addresses are adequate for most systems and ensure reliable operation with minimum complexity and confusion.

- Assign a unique node address to each server in the system, beginning at node address 0 (zero).
- Use incrementing values for each additional server on the SRM.
- Assign unique node addresses for each workstation, beginning at address 10 (assuming there are no more than 10 servers in the system). Assign addresses from 10 to a maximum of 63, one address for each workstation.

---

### NOTE

Never assign node address 0 to any workstation since this could cause a system malfunction. Address 0 is reserved as a default server address.

---

## Exceptions

- Duplicate node addresses can be assigned in the same system PROVIDED that no two computers having identical node addresses are connected to the same multiplexer or communicate on the same coax link.
- Assignment of duplicate node addresses in a system is strongly discouraged since you risk system malfunction whenever you move a computer or rearrange cabling. The two computers with identical addresses may inadvertently end up communicating with the same multiplexer or communicating on the same coax link.
- If any workstation has more than one resource management interface, all interfaces in the workstation can be assigned the same node address, provided the address does not conflict with any other computer sharing those links.

---

## Site Preparation Checklist

To make the actual hardware setup go smoothly, use the following checklist to verify that all preparatory tasks have been completed. For more information, refer to your SRM planning information.

- If needed, any special rooms or acoustically isolated areas for the server and its peripherals have been installed and are complete.
- EMI/RFI shielding has been installed, if needed.
- Conduits are in place for all system cables, if needed.
- Coaxial cables have been run through conduits and ducts in observation of local building codes, and the T connectors have been or are ready to be installed at the workstation and server locations. Both ends of the entire coax link should be terminated with 50 ohm terminators, and one end should be grounded to earth.
- At least one metre of coax cable exists between adjacent workstations and servers on the coax link configuration.
- Any special protective enclosures for cables that run across aisles or walkways have been delivered to the site and are installed or are ready to install.
- Adequate provision has been made for front, side, and rear clearances for all equipment in the system, allowing for service and operator access as well as ventilation.
- If floors or other structural components near the equipment are subject to significant vibration, HP representatives have been contacted for recommendations.
- Provision has been made to maintain ambient air within the specified range of temperature and humidity under all normal building conditions and during different seasons of the year.
- All power circuits have been properly sized and installed, and the receptacles are labelled to show which equipment connects to each.
- All electrical receptacles have been checked for proper wiring and correct ground connections. They have also been tested for contact tension including the ground terminal. Ensure that all exposed metal connectors (such as T-connectors and the ungrounded terminator) are isolated or insulated so that they do not touch any surrounding metal or conducting surfaces.
- Devices requiring dedicated circuits, such as the HP 2608A Line Printer, have been accommodated.

## Network Grounding

It is highly recommended that you check for proper grounding before you make initial connections between the coax cable and the SRM servers or workstations. It is best to have someone trained in properly grounding systems do this.

Use the following procedure to verify that there is no significant voltage difference between the grounded coax cable and the chassis ground of each server and workstation. The procedure is based on these assumptions:

- Servers and workstations are plugged into electrical outlets at their final locations, but are turned off.
- Servers and workstations are not connected to the coax cable.

To check for voltage differences:

1. Use a voltmeter to measure the DC and AC voltage between the chassis of each node and the coax cable shield. A convenient test point on the chassis is a thumbscrew holding an I/O board in place. A convenient test point on the coax cable shield is any of the metal T-connectors along the cable.
2. Ideally there should be zero volts between the chassis of each node and the coax cable shield. If any measurement is above one volt, there is a potential for data corruption on the network. To reduce voltage potential between grounds, consult your local building electrical code inspector or your local HP sales office.

# Server Installation

## Introduction

This chapter gives a brief overview about the server available for use on the SRM and how the server is physically connected to the SRM. You may want to use the server backplane diagrams and system configuration worksheets provided in Appendix D.

Installation information for SRM systems based on 9826 or 9920 configurations have been omitted from this manual because the 9826 and 9920 configurations are no longer available. However, existing 9826 or 9920 configurations are still supported.

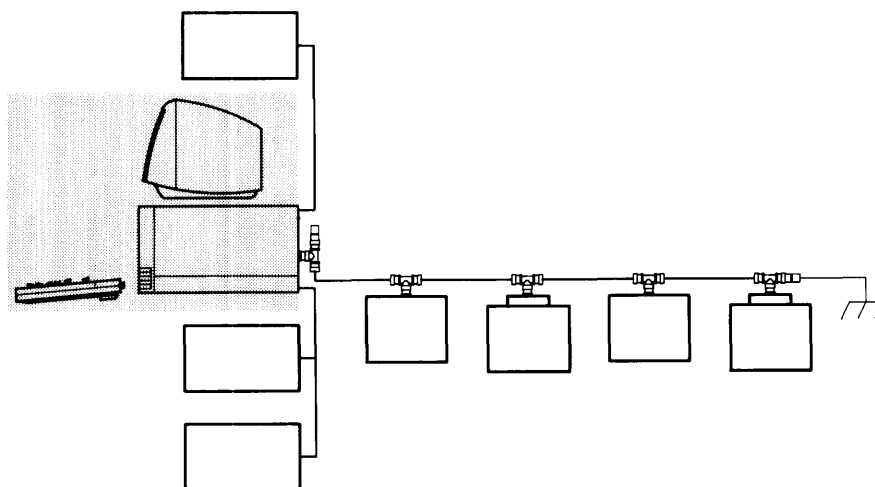

## Types of SRM Servers

The server is the heart of the SRM system, running special SRM software to manage the data communication links to user workstations and handling all mass storage and I/O activities related to the operation and use of shared system resources. The HP 50960A SRM server has six slots (three for I/O interfaces) accessible from its backplane.

## Server Communication on the SRM Link

The HP 50960A server communicates on the SRM system by means of an HP 50962A SRM Coax Interface or an HP 98629 Resource Management Interface with an HP 50961 Resource Management Coax Adapter.

To connect an HP 98629 Resource Management Interface within a coax network configuration, an HP 50961 Resource Management Coax Adapter can be attached to the SRM interface. A BNC T connector attaches to the coax adapter which makes it possible to connect coax cables or terminators.

---

## Using the HP 50960A SRM Server

The HP 50960A SRM server is shipped as a self-contained unit. If no changes to the factory settings are required, the server's hardware components can be installed in a matter of minutes.

### Handling Interfaces – Some Words of Caution

There are times when you will need to handle the server's interface cards. You should note the following guidelines to avoid equipment damage.

- Make sure the server's power is switched OFF before removing or installing interfaces.

---

#### CAUTION

PLUGGING OR UNPLUGGING AN INTERFACE WITH THE POWER ON CAN DAMAGE THE INTERFACE AND THE SERVER.

---

- Use protective measures including anti-static workstation and personnel grounding devices, if possible. Be especially careful when working in carpeted areas.
- Most interfaces contain components that are sensitive to damage from electrostatic discharge.

---

#### CAUTION

WHENEVER YOU REMOVE, INSTALL, OR HANDLE AN INTERFACE, HOLD IT BY ITS EXTRACTORS, EDGES, OR COVER PLATE. DO NOT TOUCH ITS ELECTRICAL COMPONENTS OR TRACES.

---

- If you remove an interface from an anti-static bag to view or to set switches, place the bag on a flat, dry surface and place the interface on top of the bag.

## Unpacking the HP 50960A

1. Unpack your HP 50960A SRM server from its shipping carton, carefully taking the unit from the box and removing any surrounding packing materials.
2. Place the server in its designated location with the back of the unit facing you.
3. Check the server's shipping carton **thoroughly** and remove any power cords, cables, fuses, and miscellaneous literature.

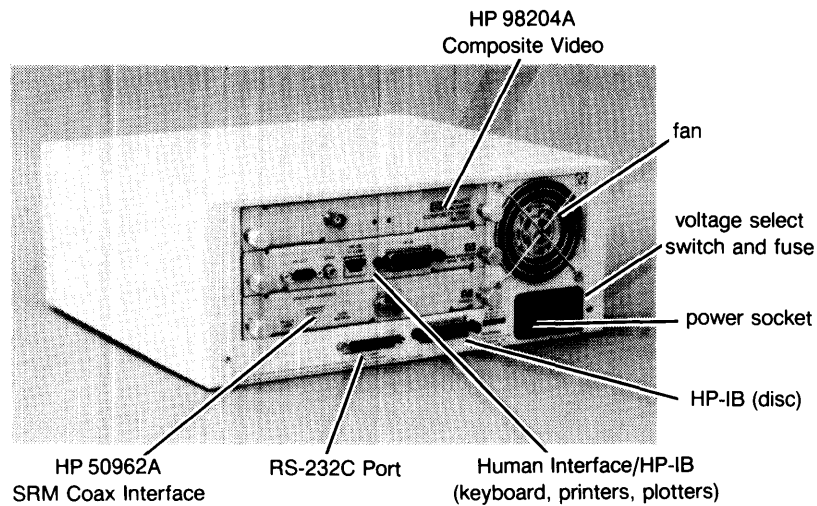
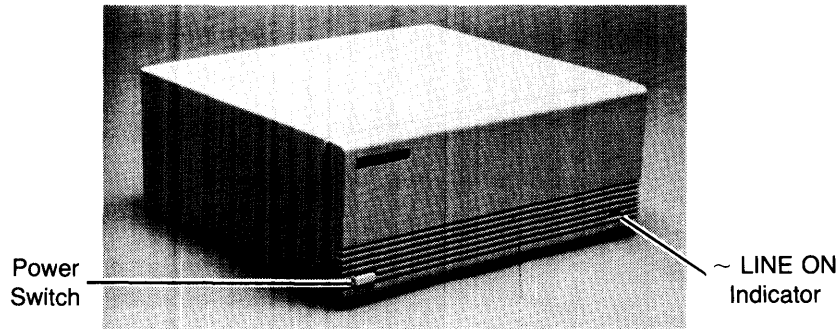

---

### Note

If your server has an HP 98629 Resource Management Interface/HP 50961 Resource Management Coax Adapter assembly, set the assembly aside until you are instructed to check or reset the switches on this interface/adaptor assembly.

---

## Checking the Voltage Select Setting

Your server can be set to operate at line voltages of 115 or 230 Vac. The voltage select cylinder on the back of the computer was set at the factory. Check with your local utility for the nominal line voltage. Then check the setting of the voltage select cylinder by reading the voltage setting visible on the back of the server.

---

### CAUTION

THE SERVER CAN BE DAMAGED IF SET FOR 115 VAC AND PLUGGED INTO A HIGHER VOLTAGE OUTLET.

---

If the setting matches your nominal line voltage, continue with “Factory Settings.” If the setting does not match the line voltage, you must change the voltage select setting as follows:

## Changing the Voltage Select Setting

1. Open the voltage select cylinder cover. Use a screwdriver if necessary.

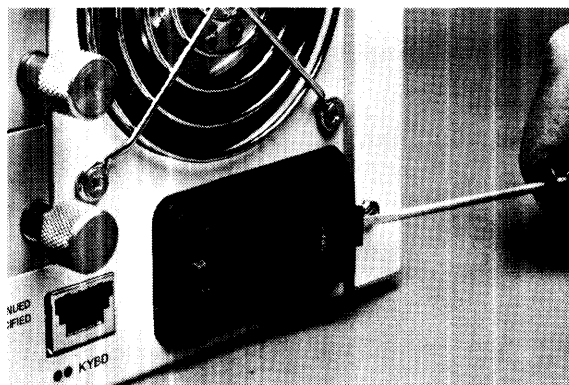

Opening the Cover

2. Remove the voltage select cylinder.

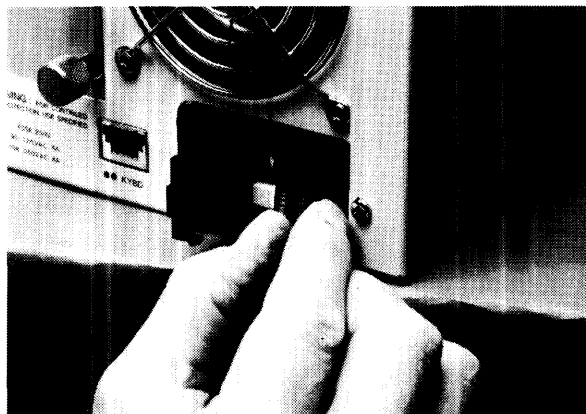

Removing the Voltage Select Cylinder



---

**Note**

The cylinder has two 115 Vac positions and two 230 Vac positions. Either position can be used for the required line voltage.

---

3. Rotate the cylinder and replace it so that the correct line voltage is visible with the cover closed.

---

**CAUTION**

ENSURE THAT THE CYLINDER IS ORIENTED CORRECTLY.  
OTHERWISE, YOU COULD DAMAGE THE SERVER.

---

4. Close the cover by pushing firmly on it with your thumb.

## Factory Settings

The HP 50960A server is shipped from the factory with three interfaces inserted. All interfaces are preset with the following values:

### HP 98204C Composite Video Interface

This interface is shipped with 50960A servers ordered without an option.

Switches:

60 Hz

(see the “HP 98204C Composite Video” section for more information about switch settings)

### HP 98546-66571 Composite Video Interface

This interface is shipped with 50960A servers ordered with option 001.

Switches:

60 Hz

(see the “HP 98546-66571 Composite Video” section for more information about switch settings)

### HP 98561-66532 Human Interface/HP-IB

Switches:

System Control (SC)                      1001

Select Code: 7

### HP 50962A SRM Coax Interface

Switches:

Remote (R)                                      true (1)

Interrupt Level (INT)                      4 (01)

Select Code (Sel. Code)                      21 (10101)

Node Address (Node Addr.)                      0 (000000)

Other factory settings you should be aware of are:

**High-Speed HP-IB disc interface** (built-in)

Select Code: 8

**RS-232 serial port** (built-in)

Select Code: 2

**Voltage select:** 115 Vac

These settings are all that is needed for a single-server SRM system. Additional servers on the same SRM system will require unique node addresses.

The following pages discuss how to check and reset the switches and how to install each of the SRM server I/O interfaces and memory boards. If you have no special configuration needs (such as resetting select codes or node addresses, or installing extra memory), skip to the section, "Installing the HP 46020A or HP 46021A HP-HIL Keyboard," for adding the rest of the server's accessories.

If your server has an HP 98629 Resource Management Interface/HP 50961 Resource Management Coax Adapter assembly, you should turn to the section, "HP 50962A SRM Coax Interface."

## Interface and Memory Configuration Switches

The interface and memory configuration switches are manufactured as clusters of two to eight individual switches combined in a single molded plastic housing. Rocker switches may be flush with the housing, or they may protrude above the housing on one side or the other. The switch value is always determined by which end of the rocker is depressed. If the switch is a slider or a flip switch, the switch value is determined by the position of the tab on the switch.

The following illustrations show how to interpret switch settings correctly; each of the four clusters have identical settings.

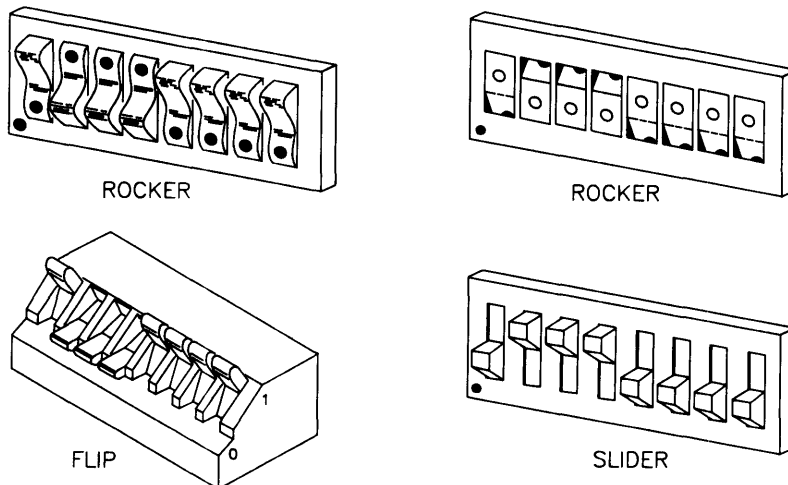

To set rocker switches, use a ballpoint pen or other pointed tool to depress each switch rocker until it is fully seated. Slide switches and flip switches can be changed by using your fingers or a suitable tool such as a small screwdriver. If the rocker, slider, or flip switch is not fully seated, the memory card or the whole SRM system may not function properly.

## Extra RAM Memory

You may want to add extra memory to your SRM system for the following reasons:

- If you want your SRM system to support serial printers and to have on-line backup. This requires 768K bytes of memory.
- If you want improved performance and support for additional devices, open files, spoolers or users, you can add up to a total of 1.5Mbytes of memory.

Having total memory of 1.5 Mbytes improves the performance of backup and restore operations, as well as supports maximum system configurations and system performance.

Two different memory boards are available for SRM systems:

- the HP 98257A 1Mbyte RAM Memory Board and
- the HP 98256A 256K-byte RAM Memory Board.

Do **NOT** install any RAM memory board in an HP 9888A Bus Expander. The SRM system does not support installation of RAM memory boards in bus expanders. Instead, you must install all RAM memory boards in the HP 50960A server's backplane.

The HP 50960A server backplane can hold:

- three 256 Kbyte RAM memory boards or
- one 1-Mbyte RAM memory board.

The latter configuration supports the maximum amount of memory 1.5 Mbytes, usable by the SRM system (the 50960A processor board already holds 512 Kbytes of memory).

### HP 98257A 1Mbyte RAM Memory Board

The HP 50960A can hold one 1Mbyte memory board behind the coverplates of the I/O interfaces.

When installing a 1Mbyte memory board, you have to set two different sets of switches:

- the switch pack on the 1Mbyte memory card and
- the RAM switch pack on the server's CPU.

To set the switches and install the 1Mbyte memory card:

1. Make sure the HP 50960A is turned OFF.
2. Carefully remove the memory board from its shipping box. When removing the board from its protective antistatic bag, grasp the board firmly by the extractor tabs or handle only the edges of the board.

- Place the board on a smooth, dry, static-free surface, oriented as shown in the diagram below.

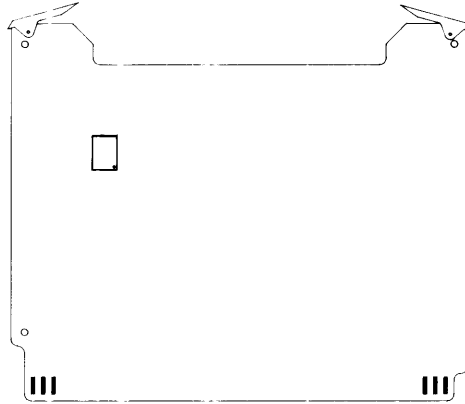

**HP 98257A RAM Memory Address Switches**

- Set the address switches as shown in the diagram below.

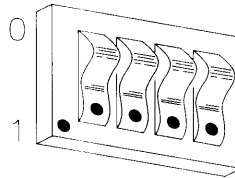

**Memory Board Switch Setting**

- Before you install the memory board in the server, you must set the RAM switches on the server's CPU. Remove all I/O interfaces from the server's backplane. Place the interfaces on smooth, dry, static-free surfaces. Handle the interfaces by the edges of the boards.

6. The RAM switch pack is located on the CPU as shown in the diagram below.

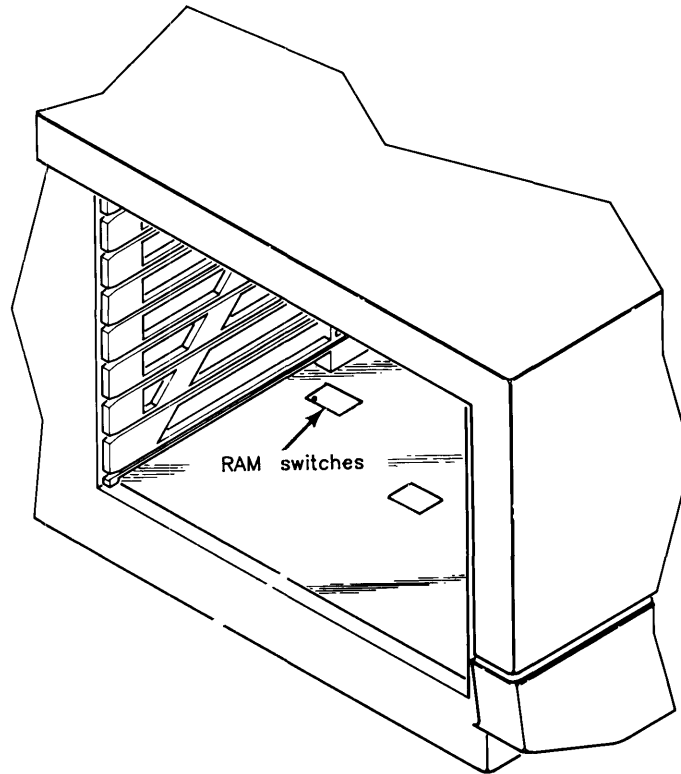

**Location of RAM Switches on CPU**

7. Set the RAM switches as shown in the diagram below.

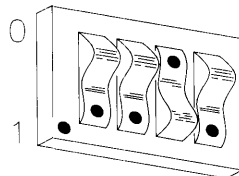

**CPU Board RAM Switch Setting**

8. Insert the 1Mbyte card first. It is recommended that you use the second slot from the bottom. If you look closely at the space in the server's blackplane, you can see that there are actually two slots. Firmly grasp the extractors on the memory board and carefully insert it into the upper slot. Slide the board in until it meets some resistance.
9. With the extractors folded flat against the edge of the memory board, press evenly and firmly on the extractors with your thumbs until the board is seated.
10. Grasp the thumbscrews or the coverplate of the I/O interface from the lower slot and insert it into the slot just below the memory board. Gently slide it into place until the screws are aligned with the screw holes.
11. Simultaneously turn both thumbscrews until tight and the coverplate is flush with the back of the server. This interface serves as the cover for the memory board.
12. Now replace all the I/O interfaces you removed to insert the 1Mbyte memory board.

## HP 98256A 256-Kbyte RAM Memory Board

The HP 50960A can hold up to three 256-Kbyte memory boards located behind the coverplates of the I/O interfaces. The memory boards are alternated with the I/O interfaces, beginning with an I/O interface in the bottom slot.

When installing memory, you **must** arrange the board address settings in a contiguous sequence of address blocks as indicated in the drawings that follow. The order in which the memory boards are inserted in the backplane is unimportant, but for convenience during service or troubleshooting, it is helpful to have them arranged in some logical order.

**Switch settings:** (see diagram below)

To set the switches and install a memory board:

1. Make sure the HP 50960A is turned OFF.
2. Carefully unpack the memory board from its shipping box. When removing the board from its protective antistatic bag, grasp it firmly by the red and yellow extractor tabs or handle only the edges of the board.
3. Place the board on a smooth, dry, static-free surface, oriented as shown in the diagram below.

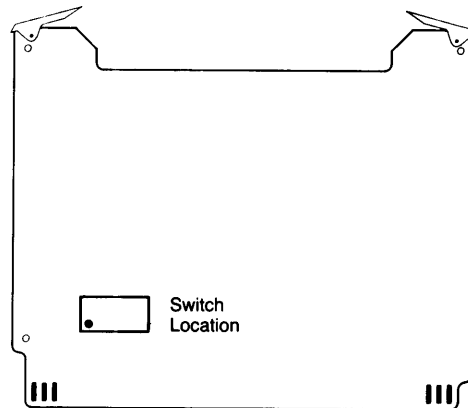

**HP 98256A RAM Memory Address Switches**

4. Set the address switches as shown in the Memory Board Switch Settings diagram below.

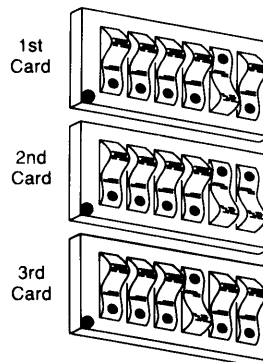

**Memory Board Switch Settings**

5. If necessary, remove an I/O interface from the server's backplane in order to uncover a slot for the memory board. It is recommended that you begin with the I/O card in the bottom position.
6. If you look closely at the space in the server's backplane vacated by the I/O interface, you can see that there are actually two slots. Firmly grasp the extractors of a memory board and carefully insert it into the upper slot. Slide the board in until it meets some resistance.
7. With the extractors folded flat against the edge of the memory board, press evenly and firmly on the extractors with your thumbs until the board is seated.
8. Grasp the thumbscrews or the coverplate of the I/O interface and insert it into the slot just below the memory board. Gently slide it into place until the screws are aligned with the screw holes.
9. Simultaneously turn the thumbscrews until tight and the coverplate is flush with the back of the server. The interface serves as the cover for the memory board.
10. Repeat steps 2 through 9 for any additional 256-Kbyte memory boards. In doing so, you may need to remove other I/O interfaces.

## Serial Communication Interfaces

Three types of serial interfaces are available for SRM servers: HP 98626 and 98644A interfaces, and the built-in serial interface on the 50960A. A serial interface allows serial printers to be connected to HP 50960A, HP 9920, and HP 9826 SRM servers.

---

### Note

If you are using an HP 50960A server, we recommend that you install your 98626 or 98644A interface in an HP 9888A bus expander.

---

### HP 98626 Serial Interface

The HP 98626 has six banks of switches, three of which must be checked. See the following photograph.

1. Gently place the interface on a dry, flat, static-free surface, oriented as shown in the photograph below.

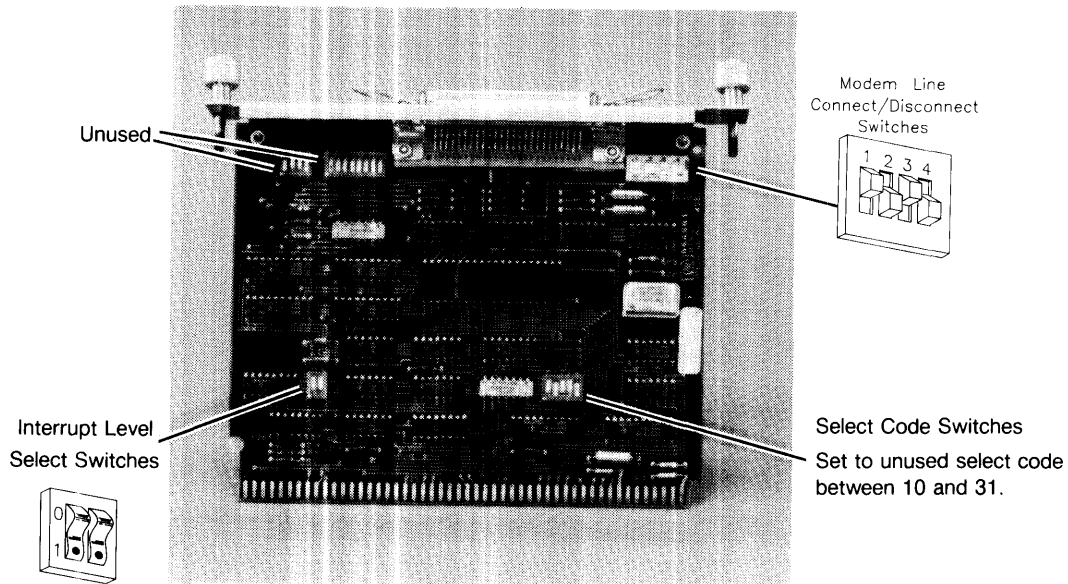

### HP 98626 Serial Interface

2. Verify the switches are set as shown. If not, use a pointed tool to set them correctly. Be sure the interrupt level for this interface is set to 6 (switch setting 11).
3. Pick up the video interface by its thumbscrews or coverplate and align it with its slot in the 9888A bus expander (when using a 50960A server), or in the 9920 or 9826 server backplane. Gently slide the interface in until the thumbscrews are lined up with the screw holes.
4. Tighten both screws simultaneously until the interface coverplate is flush with the back of the server.

### HP 98644A Serial Interface

The HP 98644A has a single bank of switches. Four of these switches must be checked:

- interrupt level = 6 (Switch setting is 11)
- select code = unused value between 10 and 31
- emulation mode = 98626 (Switch setting is 0 if the interface will be used with a printer. Switch setting is 1 if it will be used to shut down the server when power is lost.)
- modem enable = 1



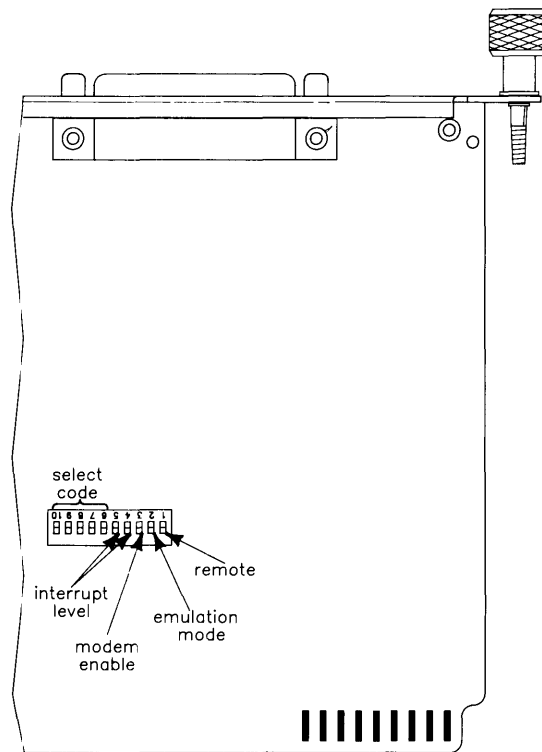

### HP 98644A Serial Interface

1. Gently place the interface on a dry, flat, static-free surface.
2. Verify the switches are set as shown. If not, use a pointed tool to set them correctly. Be sure the interrupt level for this interface is set to 6 (switch setting 11).
3. Pick up the video interface by its thumbscrews or coverplate and align it with its slot in the 9888A bus expander (when using a 50960A server), or in the 9920 or 9826 server backplane. Gently slide the interface in until the thumbscrews are lined up with the screw holes.
4. Tighten both screws simultaneously until the interface coverplate is flush with the back of the server.

### Graceful System Shutdowns

In the event of a power interruption, your system can automatically shut itself down without disc corruption. The shutdown is triggered when either a 98644A serial interface or a 9-pin RS-232 interface built into the human interface card detects a Carrier Detect modem signal.

The serial interface must be dedicated to detecting system shutdowns; it cannot be used for a printer at the same time. Use the `SYSTEM DOWN` command to dedicate the interface. (The command is described in the SRM System Manager's Guide.) Do not use an HP 98626 or the 25-pin serial interface built into the 5090A server for detecting system shutdowns. If you use an HP 98644A interface, do NOT set its switches to emulate an HP 98626.

Systems must have online backup and a standby power supply to use this feature. Power must be supplied to the server, all I/O expanders, and all disc drives until the shutdown is complete. Normally this takes less than 30 seconds. The system reboots automatically when the Carrier Detect modem signal goes away.

## The Server Interfaces

Two types of Composite Video interfaces are available for SRM servers: HP 98204C and 98546-66571 interfaces. A composite video interface converts information from the server into video signals that can be used by the video monitor.

### HP 98204C Composite Video

The HP 98204C Composite Video interface converts information from the HP 50960A server to video signals that can be used by the HP 82913A Video Monitor. The HP 50960A server uses HP 98204C Option 090, video without graphics. This is distinguished from the HP 98204C (no option number), with graphics, that is typically used in the HP 9000 Model 220 SRM server.

---

#### Note

Do NOT use the HP 98204B Composite Video interface with the HP 82913A Video Monitor. It will not work.

---

**Switch settings:** (see the following diagram)

The HP 98204C Composite Video interface has two switches to check.

1. Turn the server OFF and remove the video interface by unscrewing the thumbscrews and carefully pulling the interface straight out.

2. Gently place the interface on a dry, flat, static-free surface, oriented as shown in the diagram.

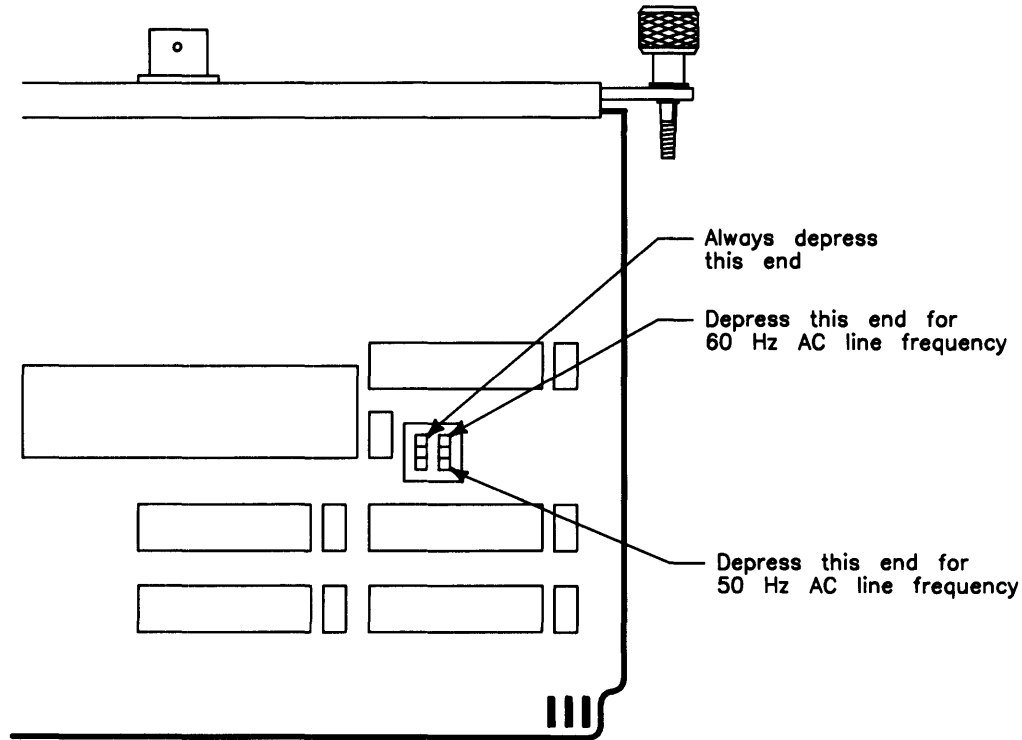

### Video Interface Configuration Switch Settings

3. Verify that the switches are set to be compatible with your AC line frequency. If they are not, use a pointed tool to set them correctly.
4. Pick up the video interface by its thumbscrews or coverplate and align it with its slot in the server's backplane. Gently slide the interface in until the thumbscrews are lined up with the screw holes.
5. Tighten both screws simultaneously until the interface coverplate is flush with the back of the server.

#### HP 98546-66571 Composite Video Interface

The HP 98546-66571 Composite Video Interface converts information from the HP 50960A server to video signals that can be used by the HP 35731B Video Monitor. This interface is installed at the factory in all new SRM servers.

The HP 98546A interface allows you to update an existing SRM system. This interface includes separate text and graphics cards.

---

#### Note

Do not use the HP 98546-66571 Composite Video Interface with the HP 82913A Video Monitor. It will not work. Similarly, do not use the HP 98204C Composite Video Interface with the HP 35731B Video Monitor.

---

To set the switches on the Video Interface:

1. Turn the server OFF and remove the HP 98546-66571 Composite Video Interface by unscrewing the thumbscrews and carefully pulling the interface straight out. Place it on a dry, flat, static-free surface.

---

**CAUTION**

MOST INTERFACES CONTAIN COMPONENTS THAT ARE SENSITIVE TO DAMAGE FROM ELECTROSTATIC DISCHARGE. USE PROTECTIVE MEASURES, INCLUDING ANTI-STATIC WORKSTATION AND PERSONNEL GROUNDING DEVICES IF POSSIBLE. BE ESPECIALLY CAREFUL WHEN WORKING IN CARPETED AREAS.

---

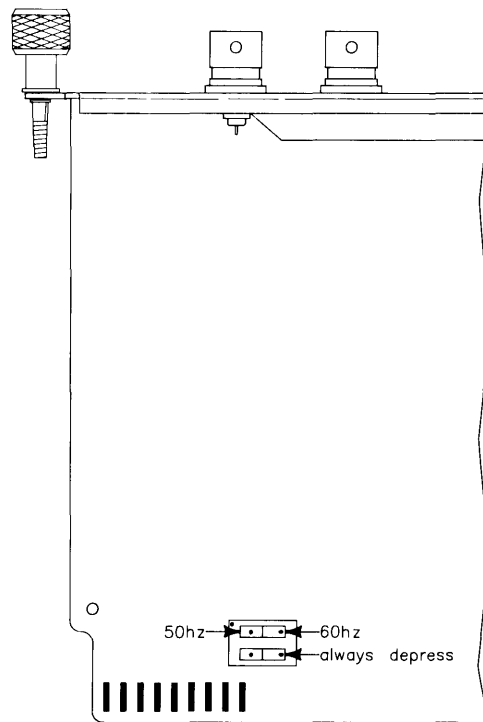

**HP 98546-66571 Composite Video Interface**

2. The 50/60 switch should be compatible with your AC line frequency. If not, use a pointed tool to set it correctly. To do this, depress the switch rocker on the end indicated in the diagram below. In the example the switch is set to 60 Hz.
3. The CHAR SELECT switch should be set to 0. If not, use a pointed tool to set it correctly as shown in the diagram below.
4. Gently slide the interface back in the HP 50960A server. Tighten both screws simultaneously until the interface coverplate is flush with the back of the server.

## Human Interface/HP-IB

The HP 50960A uses the HP 98561-66532 Human Interface/HP-IB interface which makes it possible to plug in the HP 46020A or HP 40621A HP-HIL Keyboard. The HP-HIL Keyboard plugs into the keyboard connector and HP-IB printers and plotters plug into the HP-IB port on this interface. The RS-232 serial port on this interface is not supported. (See the "Peripheral Installation" chapter for more details about installing printers and plotters.) The select code for this HP-IB port is 7.

### Switch settings:

System Control (SC)                      1001

To check the switches on the Human Interface/HP-IB interface:

1. Turn the HP 50960A OFF.
2. Remove the keyboard/HP-IB interface by unscrewing the thumbscrews and carefully pulling the interface straight out.
3. Gently place the interface on a dry, flat, static-free surface, oriented as shown in the photograph below.

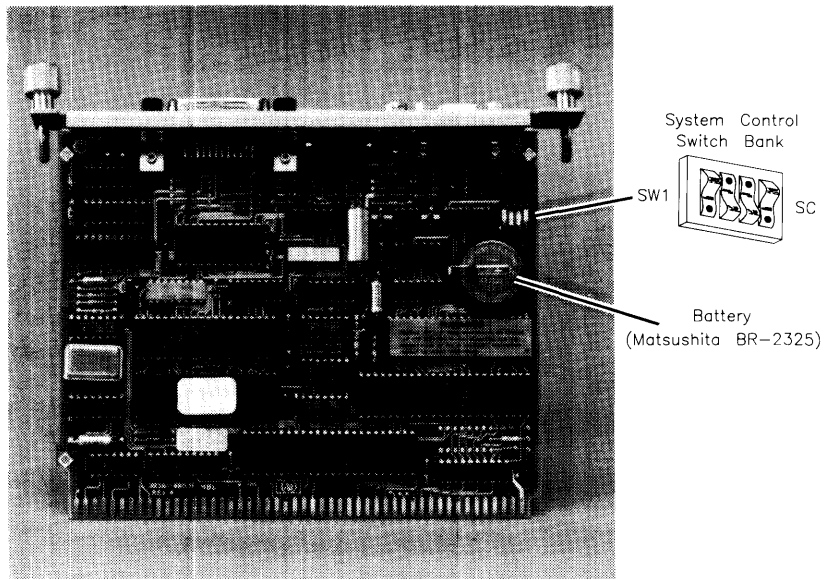

### Human Interface/HP-IB Switch Settings

4. The four switches on this interface should be set according to the illustration above. If they are not set in this configuration, depress the switch or switches.
5. Ensure the battery (Matsushita BR-2325, HP Part Number 1420-0314) is installed (see illustration). Battery life is 1-1/2 years.

---

**Note**

Do not install the 98651-66532 interface into a 9888A Bus Expander.

---

6. Pick up the keyboard/HP-IB interface by its thumbscrews or coverplate and align the board with its slot in the server's backplane. Gently slide the interface in until the thumbscrews are lined up and ready to catch on the backplane.
7. Simultaneously tighten both thumbscrews until the interface coverplate is flush with the back of the server.

### HP 50962A SRM Coax Interface

The HP 50962A SRM Coax Interface has switch settings for select code, interrupt level, and node address. The SRM interface used in an HP 50960A server must be set as follows:

	Value	Switch Setting
Remote (R)	true	1
Interrupt Level (INT)	4	01 <sup>1</sup>
Select Code (Sel. Code)	suggested range: 21 through 31	
Node Address (Node Addr.)	0, for the first server	000000

To check or reset the switches on the SRM interface:

1. Turn the server OFF.
2. If necessary, remove the interface from the server by unscrewing the thumbscrews and carefully pulling the interface straight out.
3. Pick up the interface by its coverplate and place the interface as shown below on a flat, dry, static-free surface.
4. If this is the first, or only server, verify that the switches on the interface are set as shown below. Make any necessary corrections by depressing the appropriate switches with a ballpoint pen or other pointed tool.

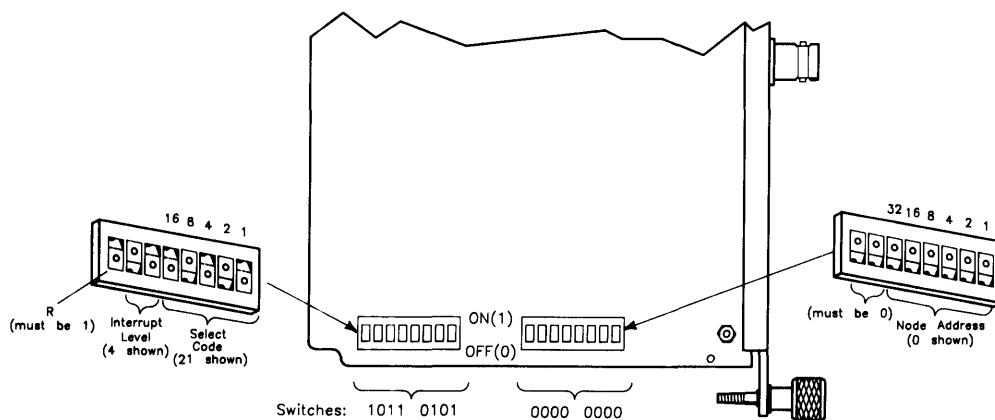

### HP 50962A SRM Coax Interface Server Configuration Switches

<sup>1</sup> Note that the two switches governing the interrupt level do NOT follow binary numbering conventions.

Note that the leftmost switch in the left cluster **must be set to 1**. Note also that the leftmost two switches in the right cluster **must be set to 00**.

The node address for the first server in an SRM system must be 0. For additional servers on the same link, you should use incrementing node addresses for each additional server. Node addresses of 0 through 9 are typically used for SRM servers. The interrupt level should always be 4. The select code for the SRM interface in each server can be the same as in other servers or can vary in the suggested range of 21 through 31. Use the system configuration worksheets in Appendix D to record server node addresses and select codes.

The tables below illustrate the correct switch settings for select codes and node addresses of servers. You can set the switches by depressing them with a ballpoint pen or other pointed tool.

#### Select Code Switch Settings

Decimal Value	16	8	4	2	1
21	1	0	1	0	1
22	1	0	1	1	0
23	1	0	1	1	1
24	1	1	0	0	0
25	1	1	0	0	1
26	1	1	0	1	0
27	1	1	0	1	1
28	1	1	1	0	0
29	1	1	1	0	1
30	1	1	1	1	0
31	1	1	1	1	1

#### Node Address Switch Settings

Decimal Value	32	16	8	4	2	1
0	0	0	0	0	0	0
1	0	0	0	0	0	1
2	0	0	0	0	1	0
3	0	0	0	0	1	1
4	0	0	0	1	0	0
5	0	0	0	1	0	1
6	0	0	0	1	1	0
7	0	0	0	1	1	1
8	0	0	1	0	0	0
9	0	0	1	0	0	1

---

### Note

Attempting to use values other than those specified in the table could result in improper system operation.

---

5. If you have an HP 50961 coax adapter, hold the coax adapter as shown in the illustration below. Use a pointed tool to set the node address on the adapter to the **same node address** used for the resource management interface.

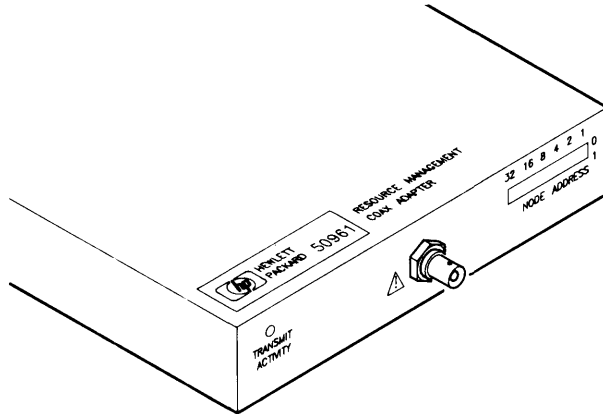

### HP 50961 Resource Management Coax Adapter

6. Attach the corresponding node address label to the interface (or to the coax adapter) where it is easily seen.
7. Pick up the interface by its coverplate. Align the board with its designated backplane slot and gently slide the interface in until the thumbscrews are lined up with the screw holes.
8. Simultaneously tighten both thumbscrews until the interface coverplate is flush with the back of the server.

## Installing the HP 46020A or HP 46021A HP-HIL Keyboard

To install the HP 46020A or HP 46021A HP-HIL Keyboard, you must have the 98561-66532 Human Interface/HP-IB interface installed in your HP 50960A server.

To install the HP 46020A or HP 46021A HP-HIL Keyboard:

1. If you haven't already done so, carefully take the keyboard out of its shipping carton, removing any surrounding packing materials. Locate the keyboard cable in the packet of supplies shipped with the HP 50960A server.
2. Make sure the HP 50960A server is turned OFF.



---

### CAUTION

THE KEYBOARD CABLE CONNECTORS ARE NOT ALIKE. IF YOU FORCE THE WRONG CONNECTOR INTO THE SERVER OR KEYBOARD RECEPTACLE, YOU CAN DAMAGE THE EQUIPMENT. CAREFULLY FOLLOW INSTALLATION INSTRUCTIONS.

---

3. Locate the end of the keyboard cable that has **two dots**. With the dots facing up, plug that end into the keyboard/HP-IB interface in the back of the server, pushing gently until it catches. The interface receptacle is also coded with **two dots**.
4. The end of the keyboard cable with **one dot** should be plugged into the **right** receptacle of the keyboard (as viewed from the back), pushing gently until it catches. The right keyboard receptacle is also coded with **one dot**.

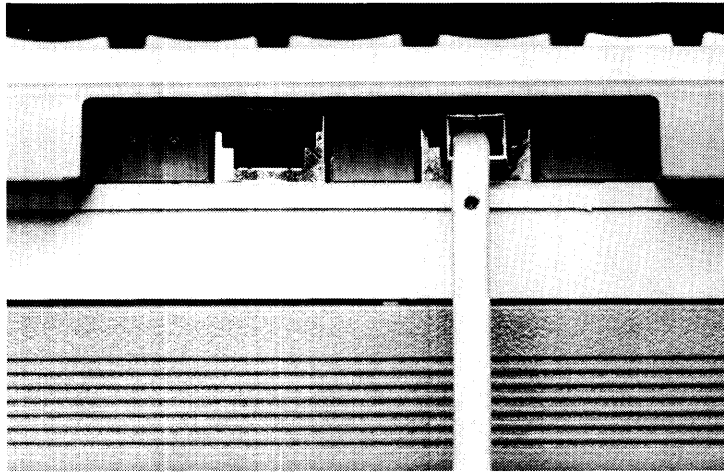

#### Installing the Keyboard Cable in the Keyboard

5. Slide the keyboard cable into the cable run on the keyboard. Position the keyboard to stand as you like.

## Installing Video Monitors

There are two video monitors available for use with SRM systems:

- HP 82913A Video Monitor
- HP 35731B Video Monitor

---

### Note

The HP 98546-66571 Composite Video Interface does not work with the HP 82913A Video Monitor. Similarly, the HP 98204C Composite Video Interface does not work with the HP 35731B Video Monitor.

---

### Installing the HP 82913A Video Monitor

To install the HP 82913A Video Monitor, you must have the HP 98204C Option 090 Composite Video interface installed in your HP 50960A server.

**Switch setting:** 75  $\Omega$

To install the monitor:

1. Carefully take the monitor from its shipping carton, removing any surrounding packing materials. Check the carton thoroughly and remove the power cord and any miscellaneous literature.
2. Verify from the specifications listed on the rear of the monitor that you have received a monitor with the proper voltage and frequency ratings for the type of local AC power supplied to your installation. If there is a problem, notify your HP Sales and Service office.
3. Ensure that the monitor's power switch is in the OFF position. This switch is the top knob on the front of the monitor and should be turned counter-clockwise as far as it can go.

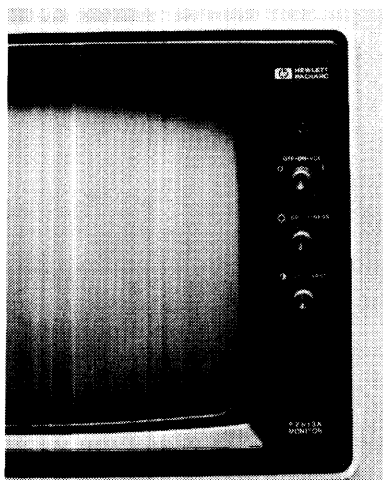



6. With the server turned OFF, plug the other end of the video cable into the composite video interface in the back of the server. Twist the cable end slightly until the cable is locked into place.



7. Connect the monitor's power cord to its power socket and plug the cord into an AC power outlet.
8. Connect the server's power cord to its power socket and plug the cord into an AC power outlet.

Your HP 50960A SRM server is now set up and ready for you to connect its peripherals. Turn to the "Peripheral Installation" chapter.

### **Installing the HP 35731B Video Monitor**

The HP 98546-66571 Composite Video Interface must already be installed in the HP 50960A server before you install the HP 35731B Video Monitor. To install the Composite Video Interface, refer to the instructions earlier in this chapter.

To install the monitor:

1. Carefully take the monitor out of its shipping carton. Remove any surrounding packing materials. Check the carton and take out the power cord and product literature.
2. Refer to the instructions provided with the HP 35731B monitor. Verify that the power cord and voltage setting are both correct for the type of AC power supplied to your installation.
3. Make sure the monitor is turned OFF.

4. Find the video cable in the packet of supplies shipped with the HP 50960A server. Plug the pin connector end of the video cable firmly into the VIDEO IN receptacle on the back of the monitor.

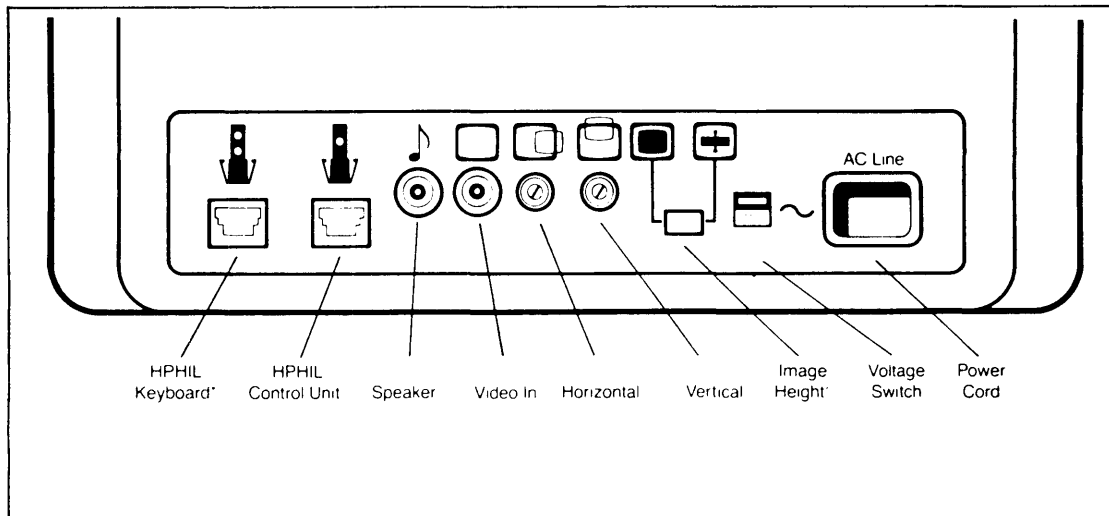

---

**Note**

The SRM system does not use the SPEAKER receptacle on the back of the monitor.

---

5. With the server turned OFF, plug the other end of the video cable into the MONITOR connector on the HP 98546-66571 Composite Video Interface. Twist the cable end slightly until the cable locks into place.

---

**Note**

The SRM system does not use the VIDEO IN connector on the back of the HP Composite Video Interface.

---

6. Connect the power cord for the monitor to its power socket and plug the cord into an AC power socket.

7. Connect the power cord for the server to its power socket and plug the cord into an AC power socket.

---

**Note**

The keyboard should be connected directly to the keyboard interface in the HP 50960A server. Do not connect the keyboard to the HP 35731B Video Monitor.

---

Your HP 50960A SRM server is now set up and ready for you to connect its peripherals. Turn to the “Peripheral Installation” chapter.

# Peripheral Installation

## Introduction

This chapter pertains to configuring and connecting the shared peripheral devices that are controlled by the SRM server. It contains a list of most of the peripherals supported by SRM Revision 2.0 and newer. If any of your SRM peripherals are not found in this chapter, verify with your local HP Sales and Service office that the peripheral is supported on SRM and ask if there are any specific configurations you should use.

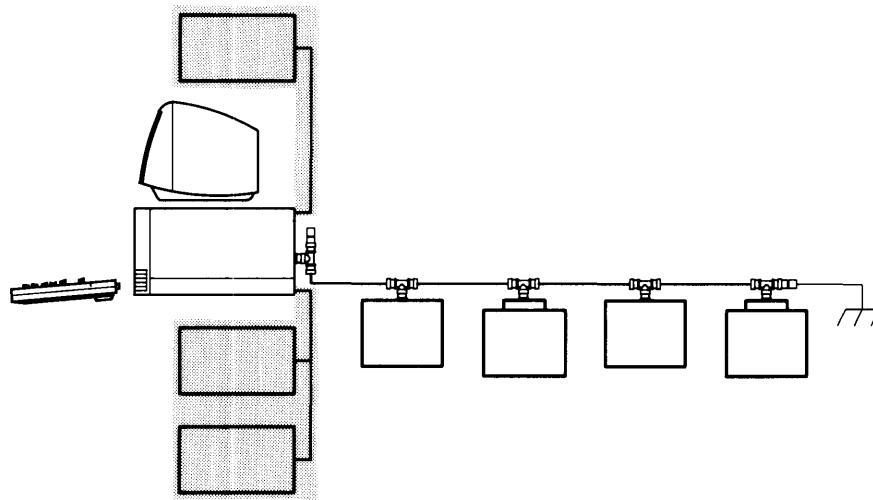

Peripherals can be connected locally to a workstation, even when that workstation is connected to the SRM. However, that configuring information is not covered here. You should instead consult the installation guide for the peripheral and the user guide for the workstation.

Once the server's memory boards and interfaces have been configured and installed, you are ready to connect the server to its shared peripherals. This chapter is divided into three sections: mass storage devices, printers, and plotters. If your system contains more than one server, the procedures outlined in this chapter apply to each server in the system. Record information for each peripheral according to the system configuration worksheets in Appendix D.

# Mass Storage Devices

An SRM system is unusable without some disc mass storage. At least one, and no more than four, mass storage devices must be included from the supported mass storage list below. Either a tape or floppy disc drive must be included in the system for SRM operating system installation and disc backup.

SRM Mass Storage Devices

Product Number	SRM 2.0 & newer	SRM 2.1 & newer	SRM 3.0 & newer	SRM 3.1 & newer	SRM 3.2 & newer	Comments
35401A			X			tape only
7907A			X			removal disk
7908P/R	X					disc/tape
7911P/R	X					disc/tape
7912P/R	X					disc/tape
7914P/R	X					disk/tape
7935H			X			disc only
7936H			X			disc only
7937H			X			disc only
7941A		X				disc only
7942A		X				disc/tape
7945A		X				disc only
7946A		X				disc/tape
7957A			X			disc only
7957B				X		disc only
7958A			X			disc only
7958B				X		disc only
7959B				X		disc only
7962B				X		disc only
7963B				X		disc only
9122C				X		micro only
9122D/S			X			micro only
9133H/L option 001			X			disc/micro
9134H/L option 001			X			disc/micro
9144A		X				tape only
9145A					X	tape only
9153B			X			disc/micro
9153C				X		disc only

## Limitations

Use only an HP 10833 HP-IB cable to connect the disc interface of the server to the disc drive. This cable has additional shielding and other features to minimize RFI and noise characteristics. Cables can be ordered in various lengths.

Due to transmission line reflection characteristics and timing constraints for high data rates, the combined bus connections for your SRM mass storage devices must not exceed 11 “equivalent loads.” The high-speed HP-IB interface represents seven equivalent loads. Most mass storage devices represent one equivalent load. Therefore, up to four discs can be connected to a single high-speed HP-IB port.



In addition, the HP-IB bus length (the **sum** of the cable lengths connected to a single HP-IB port) must not exceed one metre per equivalent load on the bus, with a maximum length of 10 metres. Thus, bus length limits are as shown below (where equivalent loads indicated are in addition to the HP-IB interface's seven equivalent loads):

**HP-IB Bus Length Limits**

Equivalent Loads	Maximum Total Cable Length
1	8 metres
2	9 metres
3	10 metres
4	10 metres

### Physical Arrangement of Equipment

To minimize any problems related to high data transfer rates and data settling time and to enhance signal reliability, arrange the disc drives so that the cables are connected from drive to drive as illustrated in the diagram below.

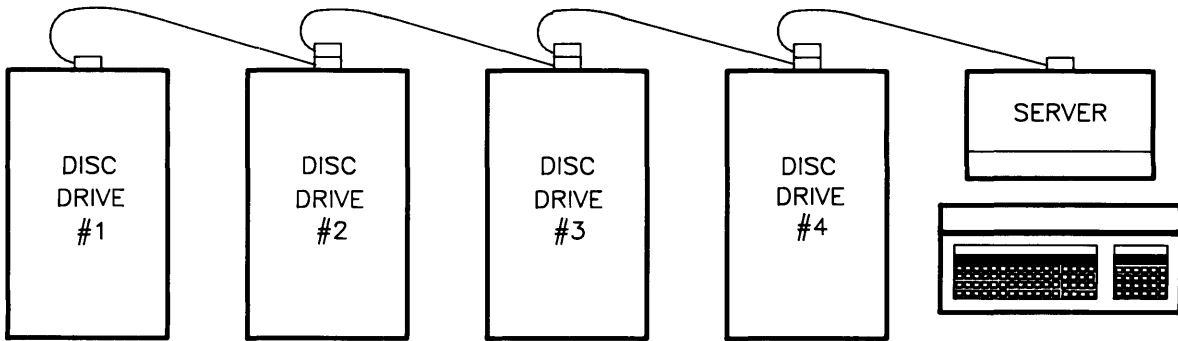

**Recommended Arrangement of Server and Disc Drives**

## Setting Up Your Mass Storage Device

Unpack and set up your shared mass storage devices. Set the necessary switches as indicated below.

When setting the switches on your mass storage device or devices, consult the literature that came with the device for the locations of the switches and other installation information. Also, refer to your system planning worksheets and the examples in Appendix B for determining what the switch settings should be.

### 7907A

1. Bus address: 0 --- 7; 0 = system disc
2. Subunit address<sup>1</sup>:
  - Fixed: 0
  - Removable: 1

### 7908P/R

1. Bus address: 0 --- 7; 0 = system disc
2. Subunit address<sup>1</sup>:
  - Disc: 0
  - Tape: 1

### 7911P/R, 7912P/R, 7914P/R

For single-controller devices:

1. Bus address (disc): 0 --- 7; 0 = system disc  
Bus address (tape): not applicable
2. Subunit address<sup>1</sup>:
  - Disc: 0
  - Tape: 1

For dual-controller devices:

1. Bus address (disc): 0 --- 7; 0 = system disc  
Bus address (tape): 0 --- 7; tape drive bus address must be different than the disc drive bus address
2. Subunit address<sup>1</sup>:
  - Disc: 0
  - Tape: 0

Each controller represents one equivalent load on the HP-IB bus.

### 7935H

1. Bus address: 0 --- 7; 0 = system disc
2. Subunit address<sup>1</sup>: 0
3. Volume configuration setting: 0

---

<sup>1</sup> Subunit address is used with the operating system software.

**7936H, 7937H**

1. Bus address: 0 -- 7; 0 = system disc
2. Subunit address<sup>1</sup>: 0
3. Set the ship-operate lever to OPERATE.

**7941A, 7942A, 7945A, 7946A**

1. Bus address: 0 -- 7; 0 = system disc
2. Subunit address<sup>1</sup>:
  - Disc: 0
  - Tape (if present): 1

**7957A, 7957B, 7958A, 7958B, 7959B**

1. Bus address: 0 -- 7; 0 = system disc
2. Subunit address<sup>1</sup>: 0

**7962B, 7963B**

1. Bus address: 0 -- 7; 0 = system disc
2. Subunit address<sup>1</sup>: 0

**9122C, 9122D**

1. Bus address: 0 -- 7; 0 = primary mass storage device
2. Subunit address<sup>1</sup>:
  - Micro: 0
  - Micro: 1

**9122S**

1. Bus address: 0 -- 7; 0 = primary mass storage device
2. Subunit address<sup>1</sup>: 0

**9133H/L option 001, 9134H/L option 001**

1. Bus address: 0 -- 7; 0 = system disc
2. Subunit address<sup>1</sup>:
  - Disc: 0
  - Micro: 1

**9144A**

1. Bus address: 0 -- 7; 0 = primary mass storage device  
If the 9144A tape drive is used with a disc drive, the bus address should be different than the bus address on the disc drive.
2. Subunit address<sup>1</sup>: 0

**9145A**

1. Bus address: 0 -- 7; 0 = primary mass storage device
2. Subunit address<sup>1</sup>: 0

Note: If the first four digits of the serial number on your tape drive are lower than 2924, you MUST upgrade the firmware in the tape drive.

<sup>1</sup> Subunit address is used with the operating system software.

### 9153B, 9153C

1. Bus address: 0 — 7; 0 = system disc
2. Subunit address<sup>1</sup>:
  - Disc: 0
  - Micro: 1

### 35401

1. Bus address: 0 — 7; 0 = primary ass storage device
2. Subunit address<sup>1</sup>: 0
3. Set the SEQ-SEL switch to **SEQ**

## Connecting the Mass Storage Device

1. After making sure the power to the SRM server is turned OFF, connect the HP-IB cable to the built-in high-speed HP-IB port on the back of the server. (Refer to the photo below.) Tighten the screws to hold the connector in place.

---

### Note

Do not connect disc drives to the HP-IB connector on the 98651-66532 Human Interface.

To connect additional mass storage devices, “daisy-chain” the HP-IB cables from device to device.

---

Connect the cable to the built-in HP-IB port, as shown.



<sup>1</sup> Subunit address is used with the operating system software.

---

### Note

The HP 35401A tape autochanger and the 9144A and 9145A tape drives may be connected to either the low speed or high speed HP-IB interface. Connecting these tape drives to the low speed HP-IB interface prevents them from interfering with faster disc drives during backups. Connecting them to the high speed HP-IB interface prevents them from interfering with printers and plotters.

Note that you cannot connect the tape drives to the low-speed HP-IB interface if your tape drive is built into a disc.

---

2. With the power to the mass storage device(s) turned OFF, connect the other end of the HP-IB cable to the HP-IB port on the back of the closest mass storage device. Tighten the screws to hold the connector in place.
3. If no other mass storage devices are to be installed in the SRM system, skip to step 7.
4. If another mass storage device (including an HP 9144A tape drive) is to be connected to the system, attach an HP-IB cable to the HP-IB cable connector on the previous mass storage device. Tighten the screws to hold the connector in place.

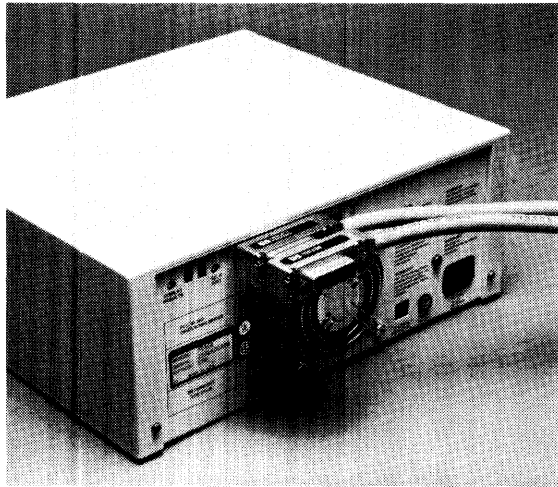

5. With the power to the next mass storage device turned OFF, connect the other end of the HP-IB cable to the HP-IB port on the back of the next mass storage device. Tighten the screws to hold the connector in place.
6. Repeat steps 4 and 5 for any additional mass storage devices.
7. Attach power cords to each mass storage device and plug the other ends into their AC power sources.

---

# Printers and Plotters

Printers and plotters are optional peripherals for an SRM system. The system can support up to eight printers and plotters, only four of which can be plotters. Connections from SRM server to printers can be made using HP-IB cables or serial (RS-232-C) cables. Connections from SRM server to plotters are made using HP-IB cables only.

---

### Note

Serial printers are supported only on the SRM System with Backup and the Disc Check Utility.

---

### Supported SRM Printers

Product Number	Interface	Product Number	Interface
2563A	HP-IB	LaserJet 500+	Serial
2608A	HP-IB	LaserJet 2000	Serial
2608S	HP-IB	LaserJet Series II D	Serial
2631B/G	HP-IB	LaserJet Series II 33440A	Serial
2932/33/34A	HP-IB	QuietJet 2227B	HP-IB
9876A	HP-IB	RuggedWriter 2235B & D	HP-IB
LaserJet 2686A	Serial	PaintJet 3630A	HP-IB
LaserJet+	Serial	DeskJet 2276A	Serial
Tempest LaserJet	Serial	DeskJet 2277A	Serial

### Supported SRM Plotters

Product Number	Product Number
7440	7586B
7550A	9872B/C
7570	9872S/T
7580A/B	7595
7585A/B	7596

## HP-IB Printers

Unpack and set up your output peripherals according to the literature shipped with each component. Verify the switch settings of each printer or plotter according to the guidelines in the following section, "Setting Up Your HP-IB Printer." For information on setting up serial printers, turn to the section titled "Serial Printers."

### Limitations

HP-IB printers and plotters must be connected, directly or indirectly, to the low-speed HP-IB port on the server's backplane using HP 10833 HP-IB cables. On the HP 50960A this port is on the keyboard/HP-IB interface. Do not connect HP-IB printers and plotters to the built-in (high-speed) HP-IB connector on the SRM server.

Most printers and plotters are classified as low-speed HP-IB devices and are considered as one unit load (u.l.) per device. The HP-IB interface in the SRM server that drives the printers and plotters is also one unit load. The length of the HP-IB bus (made up of all HP-IB cables connected to a single HP-IB port) may be up to two metres per unit load on the bus and may not exceed 20 metres. HP-IB cables between devices may be any length as long as the sum of the cable lengths on the bus does not exceed bus length limitations. For example:

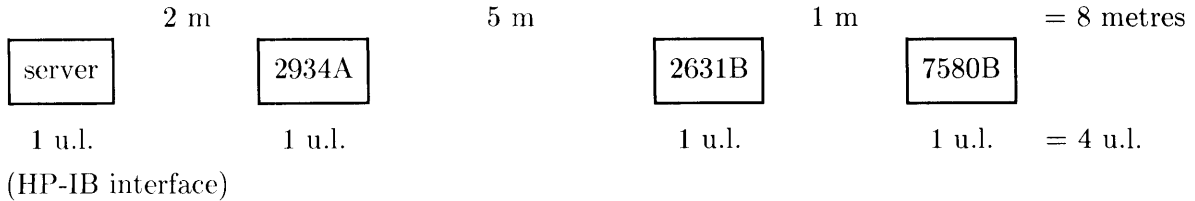

### Physical Arrangement of Equipment

HP-IB shared printers and plotters can be connected in two ways: either in a “star” pattern, where each printer’s or each plotter’s HP-IB cable connects to the server; or a “daisy-chain” configuration where only one printer or plotter connects to the server and each additional printer or plotter connects to the one before it.

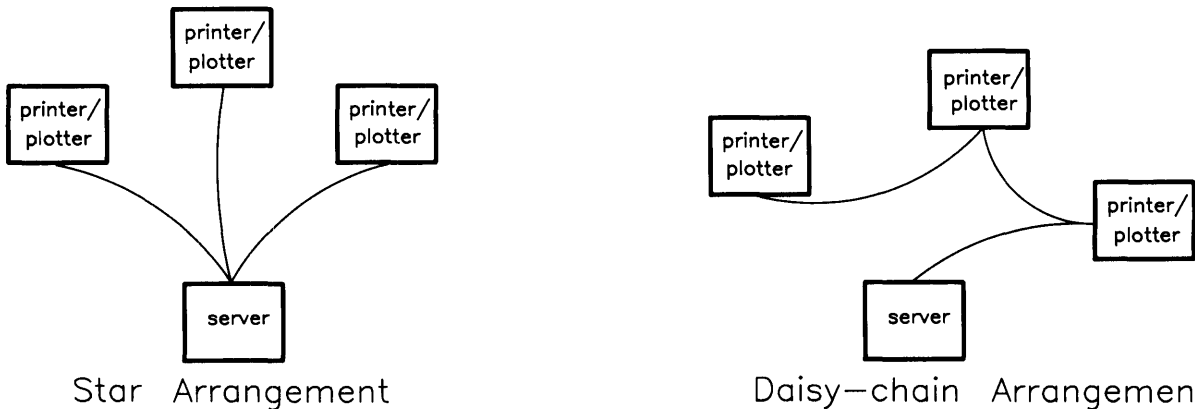

Printers and plotters can and should be connected to the same HP-IB bus. Disc and tape drives should be connected to the other HP-IB port in the server.

### Setting Up Your HP-IB Printers

When setting the switches on your printer(s), consult the literature that came with the printer for locations of the switches and other installation information. Use the following guidelines to determine the switch values for your SRM printer.

(Turn to the next section for setting up your serial printer.)

#### General Rules

1. Set each printer in the system to an **unused bus address** in the range: **0 — 7**.
2. Disable **Listen Always** mode.
3. Disable **SRQ**.

### QuietJet 2227

1. Set A1 UP to enable secondaries.
2. Set B2 DOWN to disable SRQ.
3. Set B3 DOWN to disable Listen Always.
4. Set B4, B5, and B6 to the HP-IB address (UP means 1).

### Rugged Writer 2235

1. Set B4, B5, and B6 to the HP-IB address (UP means 1).
2. Set B7 DOWN to disable SRQ.
3. Set B8 DOWN to disable Listen Always.
4. Set B9 UP to enable secondaries.

### 2563A

This printer employs a high-speed HP-IB signal exchange and has a configurable number of unit loads, from one to eight. You can use only **one** metre of HP-IB cable per unit load on the bus, up to a combined total of 15 metres of HP-IB cable.

The advantage to having configurable unit loads is that it allows you to use longer HP-IB cables. The following diagrams illustrate the relationship between unit loads (u.l.) and the length of HP-IB cables (in metres, m).

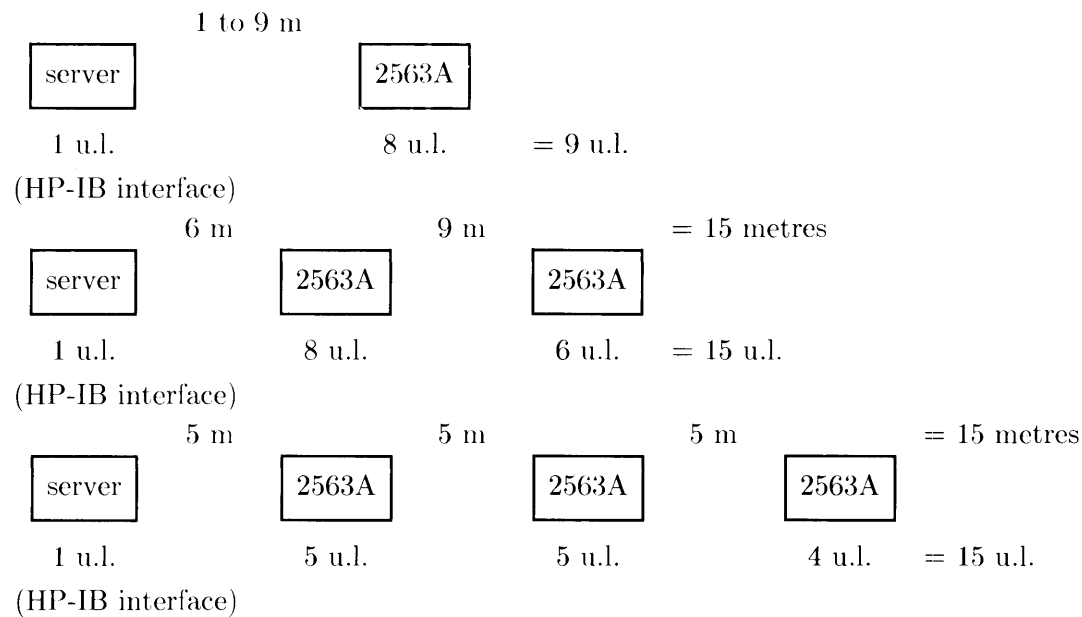



Although low-speed HP-IB devices (plotters and other printers) are allowed two metres of HP-IB cable per unit load, a low-speed HP-IB device on the same bus as high-speed devices such as the 2563A printer must conform to the high-speed specifications regarding HP-IB cable lengths: one metre per unit load on the bus, up to a total of 15 metres of cable. For example:

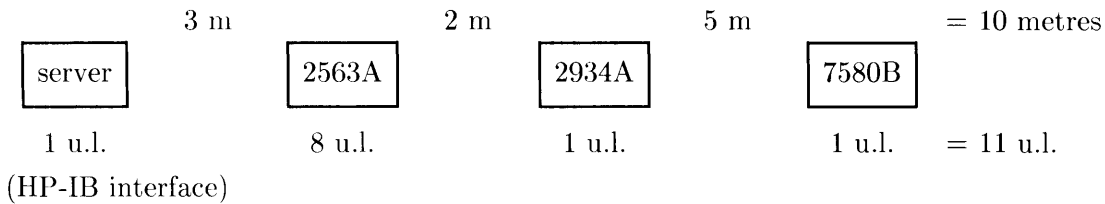

To get your HP 2563A printer ready for use on the SRM:

1. Set the bus address to an unused address between 0 and 7 using **Configure Function Number 20**.
2. Set the printer up for Ciper protocol using **Configure Function Number 25** and select **"0."** If the printer is not set for Ciper protocol, there will be problems with printer timeouts.

### **2608A**

1. Set the bus address to an unused address between 0 and 7.
2. The HP-IB interface within the 2608A has three jumpers. All three of these jumpers should be installed for SRM Revision 1.0, but the **SRQ** jumper should **not** be installed for SRM Revision 2.0 and newer. This jumper must be removed in order to use the printer on SRM systems 2.0 and newer.

### **2608S**

1. Set the bus address to an unused address between 0 and 7.

### **2631B/G**

1. Set the bus address to an unused address between 0 and 7.
2. Set Listen Always to **OFF**.
3. Set SRQ Enable to **OFF**.

### **2932A, 2933A, 2934A**

1. Set the bus address to an unused address between 0 and 7.
2. The following modes are set by using the `Modify Printer Other` command sequence.
  - a. Set Display Functions to **OFF**.
  - b. Set HP Terminal Mode to **OFF**.
  - c. Set Restricted Sequences to **NONE**.
  - d. Set Support Mode to **2632A**, **2933A**, or **2934A**, depending on the model printer you are using.
3. The following modes are set by using the `Modify Interface` command sequence.
  - a. Set Secondary Commands to **ON**.
  - b. Set Listen Always to **OFF**.
  - c. Set Service Request to **OFF**.

### **PaintJet 3630**

1. Set A1, A2, and A3 to the HP-IB address.
2. Set SCS to 1 to enable secondaries.

### **9876A**

1. Set the bus address to an unused address between 0 and 7.
2. Set Listen Always to **OFF**.
3. Set SRQ Enable to **OFF**.
4. Set 8 bit / 7 bit ASCII to **8 bit**.

## **Connecting Your HP-IB Printer to the SRM**

Attach the HP-IB cable to the keyboard/HP-IB interface as shown in the picture below.

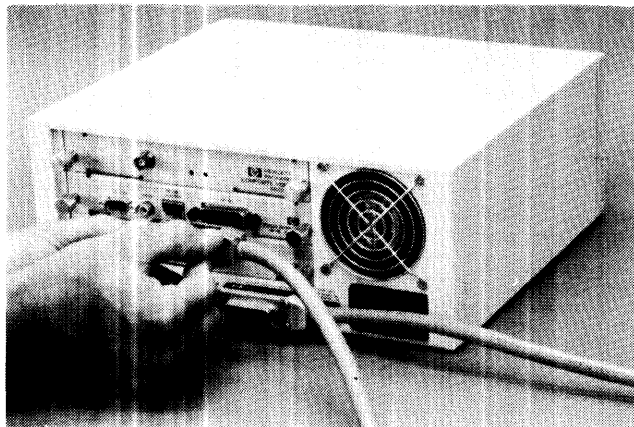

Connect additional printers and plotters in a star or daisy-chain pattern as described earlier in this section.

## Serial Printers

Unpack and set up your serial printer according to the literature shipped with the peripheral. Check the documentation and set all necessary configuration switches. Be sure the peripheral is **off** before connecting it to the server.

Server serial ports are available either:

- on the backplane of the 50960A server (built-in); or
- on the HP 98626 serial interface card (if installed) in either an HP 9920 or HP 9826 SRM server, or in an HP 50960A SRM server with an HP 9888A bus expander.

The following table gives printer configurations and appropriate cables:

For this configuration,	use these cables:
50960A built-in serial port or 98644A serial interface ↓ LaserJet and DeskJet printers	13242G  <b>OR</b> 40242G (equivalent wiring but with RFI filtering)
98626 serial interface card installed in a 9920, 9826, or 50960A w/ 9888A bus expander ↓ LaserJet and DeskJet printers	5061-4215 <b>and</b> 17255D <sup>1</sup> (shown below)  <b>OR</b> 5061-4216 <b>and</b> 40242M (only for printers that do XonXoff handshaking. Shown below.)

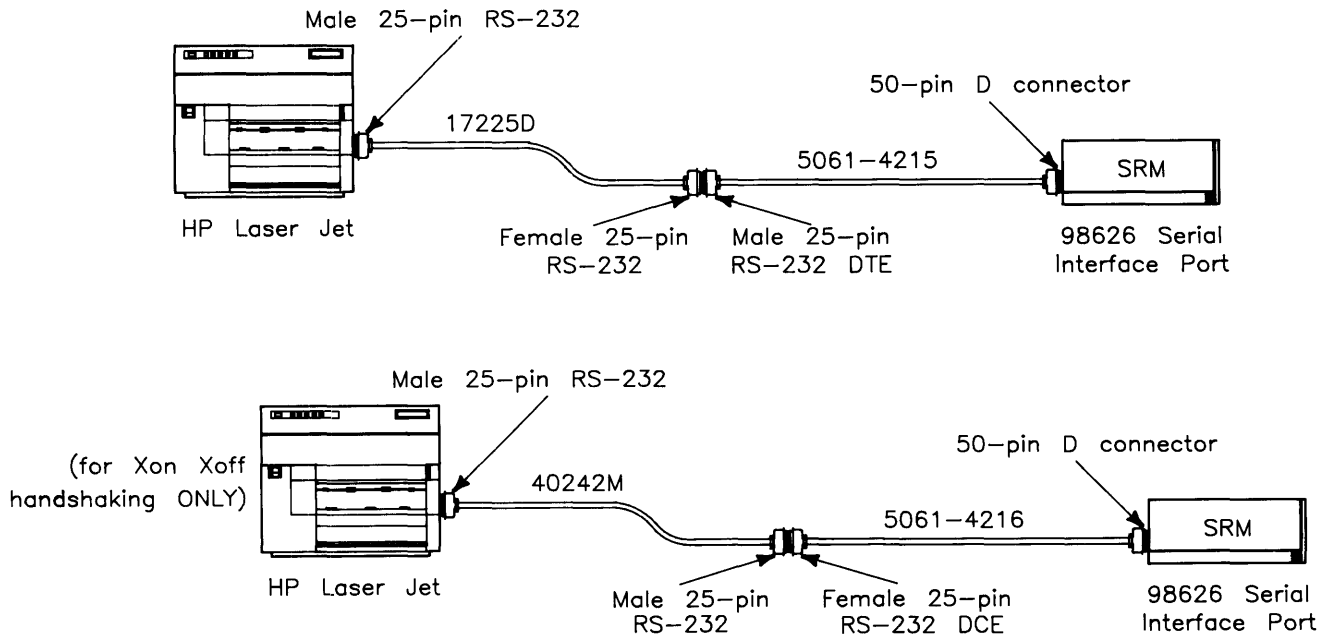

### Connecting the 98626A Serial Interface Card and the LaserJet

\* An HP 40242G (or HP 13242G) cable together with an HP 92224F female gender converter is equivalent to an HP 17255D cable and may be used in place of the HP 17255D.

## Setting up your Serial Printer

When setting the switches on your serial printer, consult the literature that came with the peripheral for location of the switches and other configuration information.

Serial connection values (baud rate, parity, data bits, stop bits, and handshake) must be set on the printer to match those set on the server. See the *SRM System Manager's Guide* for information on setting the SRM server's serial interface configuration.

### HP 50960A Built-In Serial Connector

A female 25-pin "D" connector is used for the RS-232 interface on the back of the 50960 server. Each signal line implemented conforms to EIA Standard RS-232-C specifications for voltage levels, load impedance, waveshaping, and etc. Although a female connector is used, signal connections are as specified by the standard for a male (DTE) connector. The pin assignments for the connector are defined below; pins not listed are not connected.

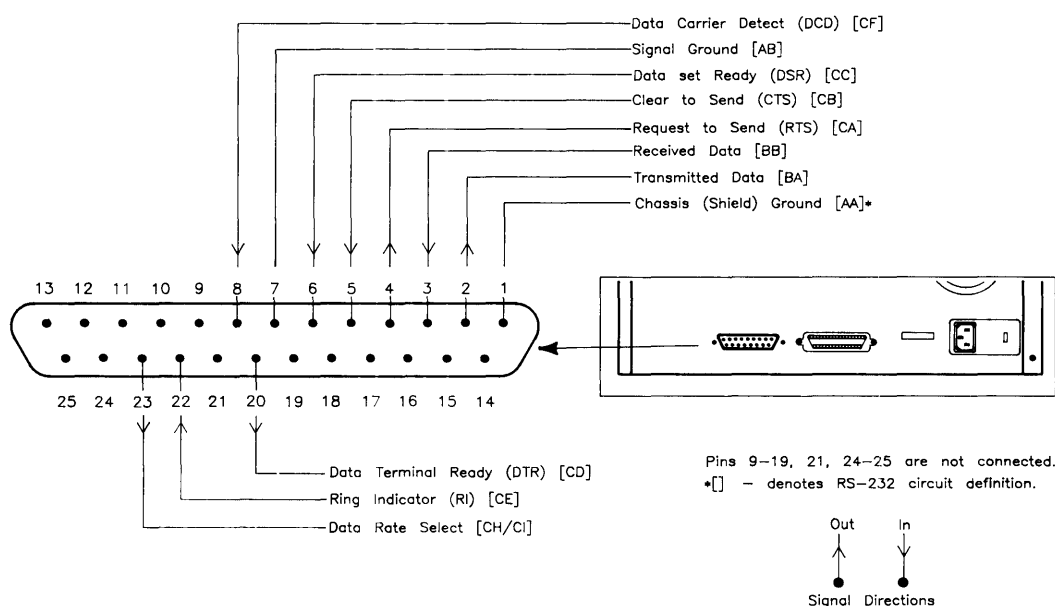

## Serial Connector Pin Assignments

The pin assignment diagrams below are provided for reference.

### 40242G or 13242G (No RFI Filter)

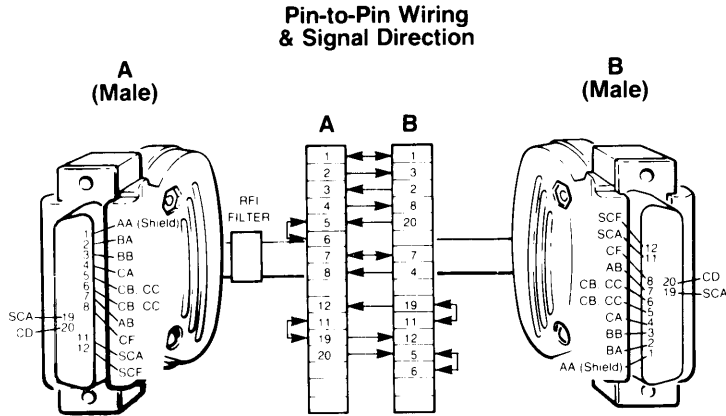

### 17255D

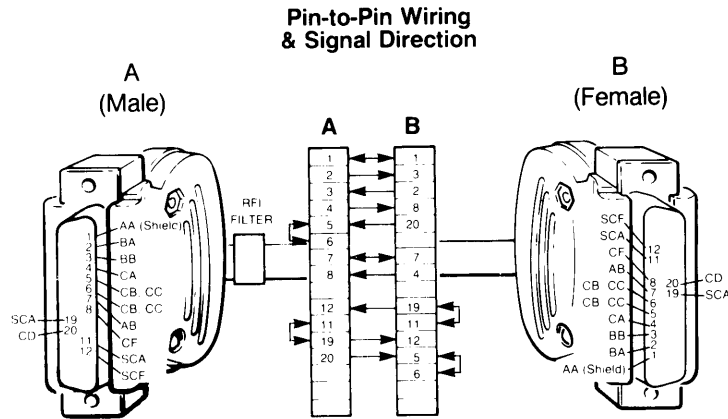

### 40242M

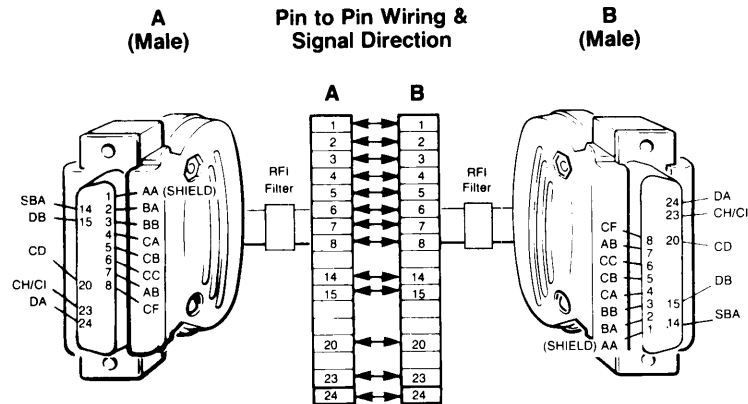

## Connecting Your Serial Printer to the SRM

Connect the appropriate serial cable to the 50960A built-in port serial port as shown below.

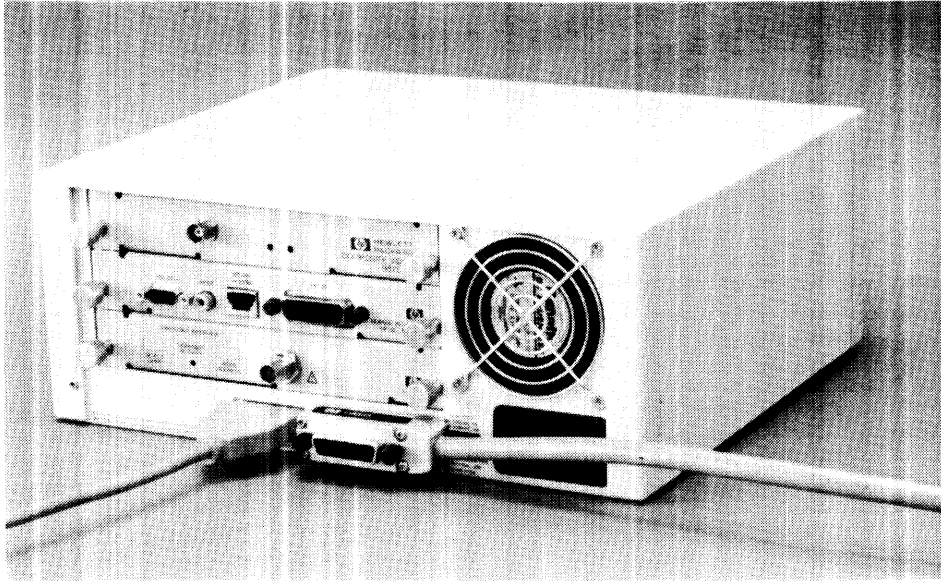

## Setting Up Your SRM Plotter

When setting the switches on your plotter(s), consult the literature that came with the plotter for locations of the switches and other installation information. Use the following guidelines to determine the switch values for your SRM plotter. Serial connections for plotters are not supported by SRM.

(Turn to the previous section to set up your SRM printer.)

### General Rules

1. Set each plotter in the system to a **unique bus address** in the range: 8 — 29.
2. Disable **Listen Always** mode.
3. Enable **SRQ**.
4. Disable secondary commands if the plotter has it.

### 7440

1. Set the bus address to an unused address between 8 and 29.
2. Set the Load and Position Paper switch to **ON**.

### 7550A

1. Use the HP-IB connector on the plotter; RS-232 is not supported by SRM.
2. Set the bus address to an unused address between 8 and 29.
3. Set Listen Only to **OFF**.
4. Set Monitor Mode to **OFF**.

### 7570

1. Set the bus address to an unused address between 8 and 29.

### 7575A, 7576A

1. Set the bus address to an unused address between 8 and 29.

### 7580A/B, 7585A/B, 7586B

1. Set the bus address to an unused address between 8 and 29.
2. Set Listen Only to **OFF**.
3. Set Emulate **as required** for the application.
4. Set Expand **as required** for the application.

### **7595/7596**

1. Set the bus address to an unused address between 8 and 29.

### **7600**

1. Set the bus address to an unused address between 8 and 29.
2. Enable the 7586 emulation mode, and disable the HPGL/2 mode.
3. When you configure a spooler for this plotter, use the BUFFERED mode for better performance. Refer to the Software Installation Manual for details.

### **9872B/C/S/T**

1. If you are using a roll-feed plotter, be sure it is full of paper before bringing up the SRM system. Otherwise, it will be configured initially as a single-sheet plotter.
2. Set the bus address to an unused address between 8 and 29.
3. Set Listen Only to **OFF**.
4. Set Confidence Test to **OFF**.

## **Connecting Your Plotter to the SRM**

Attach the HP-IB cable to the keyboard/HP-IB interface as shown in the picture below.

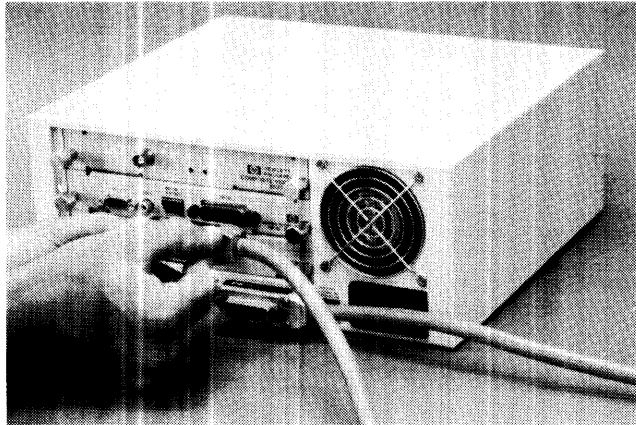

Connect additional printers and plotters in a star or daisy-chain pattern as described in the section called "Physical Arrangement of Equipment."



# The Network

## Introduction

Communication between the 50960A SRM server and the workstations is achieved through the coax network configuration which uses RG 58C/U coaxial cabling to connect servers and workstations in a bus fashion.

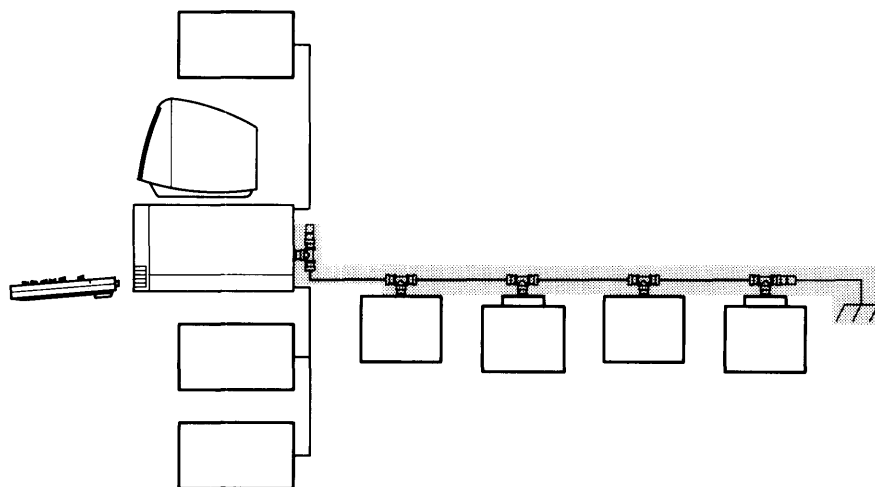

This chapter describes how the connections are made at the server site and covers the coax network configuration. Although the connection to the SRM link is essentially the same for workstations as for servers, installation of the workstations is covered in more detail in the next chapter.

By this time, you should have already laid the cables to be used to connect the SRM system. The coax network should be terminated at both ends; one end should also be grounded to earth. BNC T connectors should exist at points along the coax cable where you plan to connect the cable to a workstation or server.

---

## The Coax Network

The coax network configuration consists of the following components: coaxial cabling, with or without connectors attached (HP offers precut lengths with attached connectors, or uncut lengths to which you attach the connectors), end connectors, barrel connectors, T connectors, terminators, grounding wire, and plastic insulators.

T connectors link segments of coax cable together at points where a server or workstation is to be connected to the network. The T connector attaches to either an SRM Coax Interface or to an HP 50961 Resource Management Coax Adapter. The coax interface is inserted in the back of the server or workstation. The coax adapter attaches to an HP 98629 Resource Management Interface inserted in the server or workstation.

No special power requirements are necessary for the coax network configuration.

### Correct and Incorrect Coax Connections

The following illustration shows the correct coax network connection: the T connectors are attached to the coax interface or the coax adapter; the coax cables are attached to the T connectors; both ends of the coax network are terminated; and, one end of the network is grounded.

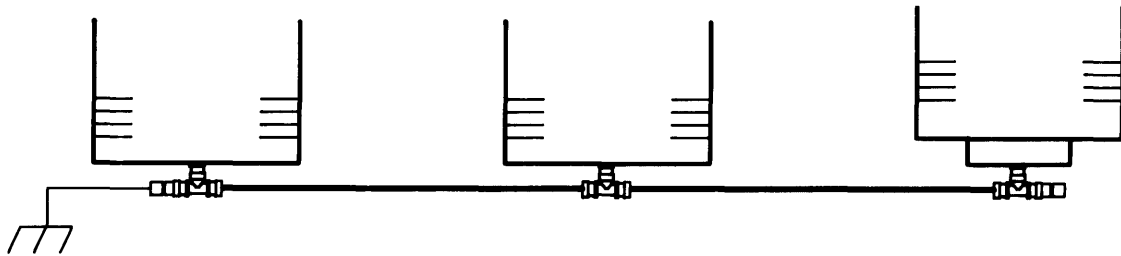

Correct Coax Connection

The next illustration of a coax network is incorrect because a coax cable cannot be connected directly to a coax adapter.

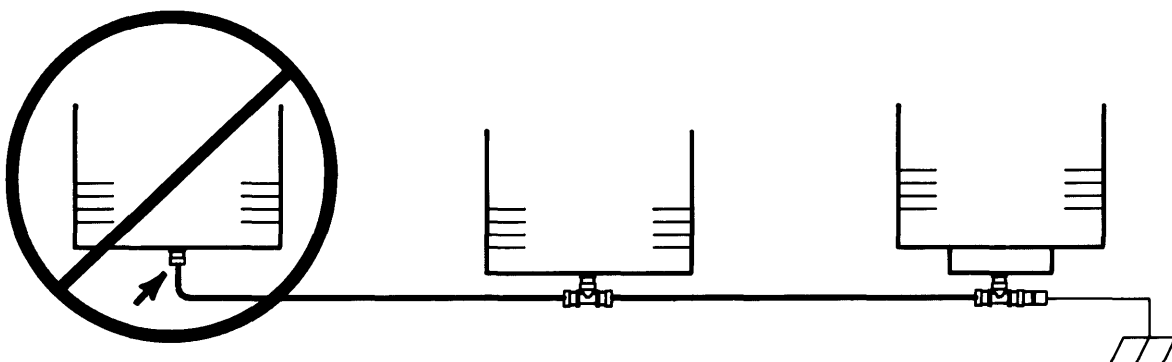

Incorrect Coax Connection

The next illustration of a coax network is also incorrect because you cannot use a length of coax cable between the coax interface or the coax adapter and the T connector.

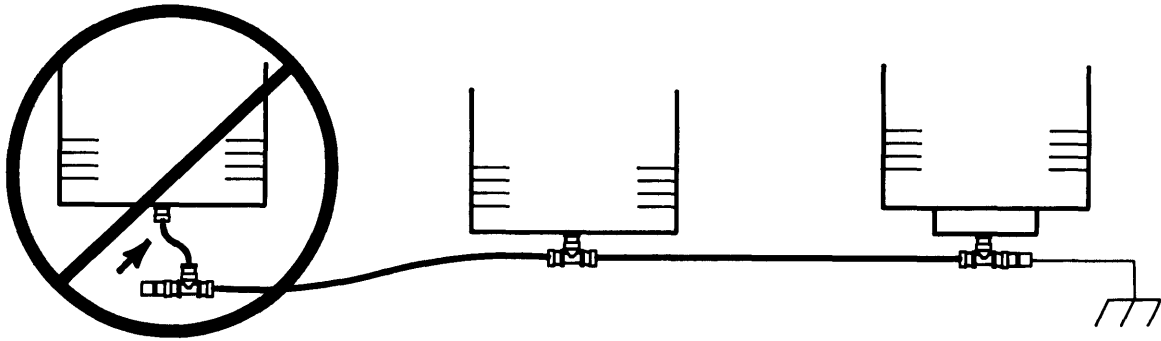

**Incorrect Coax Connection**

To assure product and personal safety, cover any exposed connectors — T connectors, barrel connectors, or terminators — on the network. Use the covers that come with the T connectors.

---

**CAUTION**

AN UNTERMINATED CABLE CAN CAUSE PERMANENT DAMAGE TO HP 50961 OR 50962A COAX INTERFACE CARDS. MAKE SURE THAT BOTH ENDS OF YOUR SRM NETWORK CABLE ARE PROPERLY TERMINATED, AND THAT ONE END IS GROUNDED. DO NOT GROUND BOTH ENDS OF THE NETWORK CABLE.

---

## **Connecting Servers to the Coax Network**

At each server location:

1. Turn the server OFF.
2. Make sure the HP 50962A SRM Coax Interface is firmly seated in the server.

If the server is using an HP 98629 Resource Management Interface/HP 50961 Resource Management Coax Adapter assembly, make sure the coax adapter is firmly attached to the interface.

3. Attach the T connector to the coax connector on the coax interface or on the coax adapter. Complete the network connection by attaching two coax cables, a cable and a terminator, or a cable and a grounded terminator to the T connector. Use a short push and a clockwise twist to lock each connector in place.

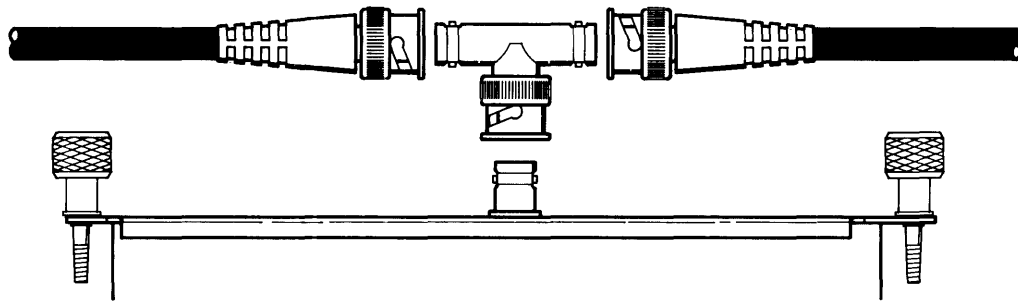

If it becomes necessary to physically disconnect the server from the coax network, do so by unplugging the T connector from the server. Leave the cables or cable and terminator connected to the T to preserve the network's continuity for other servers and workstations.

4. Cover the T connector with the insulator and snap the insulator into place.

---

#### CAUTION

TO ASSURE PERSONAL AND PRODUCT SAFETY, AN INSULATING "BOOT" MUST BE USED TO COVER THE COAX T CONNECTOR.

---

5. Repeat steps 1 through 4 for each server connection.
6. Verify that one end of the coax cable is grounded to earth. A coax terminator with a coated wire one metre long and with a flat, U-shaped end (spade lug) should be attached to a grounded source such as an AC wall outlet or a cold water pipe.

---

#### Note

A section of coax cable can be used between the last T connector and a convenient grounding source. The cable should then be fitted with a grounded terminator and the grounding wire attached to the ground source.

---

7. Cover the terminator with the insulator that came with the terminator. You could also remove the terminator insulator and cover the entire connection with an insulator.
8. Position the server, the keyboard, and the monitor as you prefer.

Your server(s) and its peripherals are now ready for use on the SRM system. Only the workstations need to be configured for the SRM. Workstation installation is covered in the next chapter.

---

## **Connecting Multiple Servers**

Connecting multiple servers to a single coax network may or may not improve the network's overall performance. Configuring an SRM network with more than one server requires planning and forethought. A separate document, the *SRM System Planning Guide*, describes this planning process, the considerations which influence it, and performance guidelines.



# Workstation Installation

---

## Introduction

This chapter explains how to install workstations to the SRM system. The greatest advantage of having SRM workstations is their ability to share data files and peripheral resources.

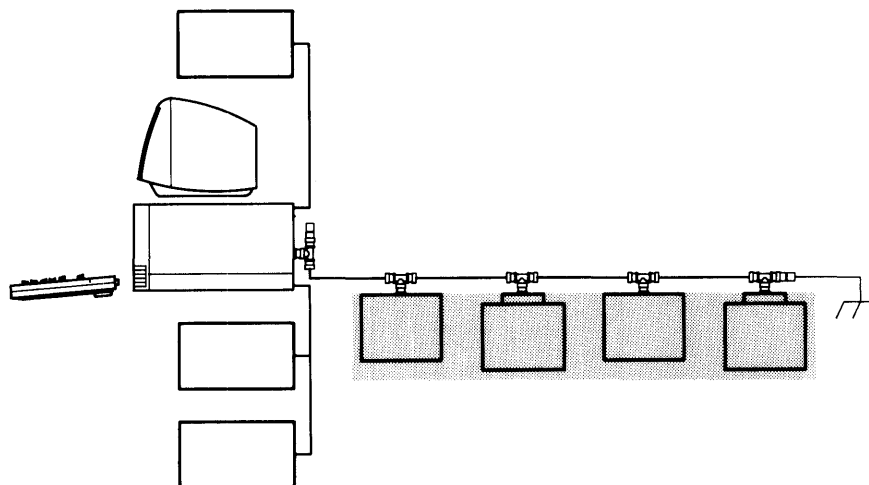

This chapter deals only with making the hardware connections necessary to connect a workstation on the SRM. You should refer to the installation and operating manuals shipped with the workstation and its peripherals for more information about using the workstation. See Appendix E for more information about the multiplexer network configuration used for HP 9835A/B and HP 9845B/C desktop computers.

## Handling Interfaces – Some Words of Caution

You should note the following guidelines to avoid equipment damage when handling any interface cards or memory boards.

- Make sure the workstation's power is turned OFF before removing or installing interfaces.

---

### CAUTION

INSERTING OR REMOVING AN INTERFACE WITH THE POWER ON CAN DAMAGE THE INTERFACE AND THE WORKSTATION.

---

- Use protective measures including anti-static workstation and personnel grounding devices, if possible. Be especially careful when working in carpeted areas.
- Most interfaces contain components that are sensitive to damage from electrostatic discharge.

---

### CAUTION

WHENEVER YOU REMOVE, INSTALL, OR HANDLE AN INTERFACE, HOLD IT BY ITS EXTRACTORS, EDGES, OR COVER PLATE. DO NOT TOUCH ITS ELECTRICAL COMPONENTS OR TRACES.

---

- If you remove an interface from an anti-static bag to view or to set switches, place the bag on a flat, dry surface and place the interface on top of the bag.



## Interface Configuration Switches

The interface configuration switches are manufactured as clusters of two to eight individual switches combined in a single molded plastic housing. Rocker switches may be flush with the housing, or they may protrude above the housing on one side or the other. The switch value is always determined by which end of the rocker is depressed. If the switch is a slider or a flip switch, the switch position is determined by the position of the tab on the switch.

The following illustrations show how to interpret switch settings correctly; each of the four clusters have identical settings.

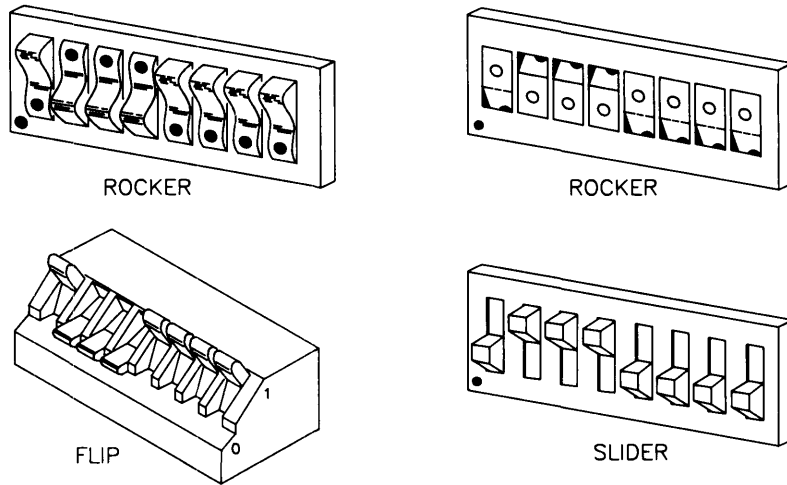

To set rocker switches, use a ballpoint pen or other pointed tool to depress each switch rocker until it is fully seated. Slide switches and flip switches can be changed by using your fingers or a suitable tool such as a small screwdriver. If the rocker or slider is not fully seated, the SRM system may not function properly.

# Installing Series 200 and Series 300 Workstations

Series 200 and Series 300 workstations<sup>1</sup> communicate with the SRM system through the HP 50962A SRM Coax Interface or the HP 98629 Resource Management Interface. The HP 50962A uses a coax network configuration. The HP 98629 can also use a coax network configuration by first attaching an HP 50961 Resource Management Coax Adapter. Without the coax adapter, the HP 98629 interface can connect to an HP 98028A Resource Management Multiplexer using a different cabling scheme. Refer to the “Introduction” of this manual for further information on cabling schemes and their hardware requirements.

Individual workstations are identified to a server by the workstation’s unique node address. These addresses are set by small switches on the resource management interface before the interface is installed in its workstation. Use your system configuration worksheets in Appendix D to record information as you configure your SRM workstations.

1. If you haven’t already done so, unpack your Series 200 or Series 300 workstation from its shipping carton. Set up the computer according to its instructions. Make all the necessary connections for any local peripherals according to their installation instructions. Situate the computer so that its backplane is accessible.
2. Carefully unpack the HP 50962A SRM Coax Interface from its shipping carton, leaving it in its protective envelope. Inspect the carton and remove any additional literature.
3. Handling the interface carefully by its coverplate and edges only, remove it from the protective envelope and place it on a dry, flat surface, oriented as shown in the diagram below.

If you have an HP 98629 Resource Management Interface, set its switches as shown for the HP 50962A.

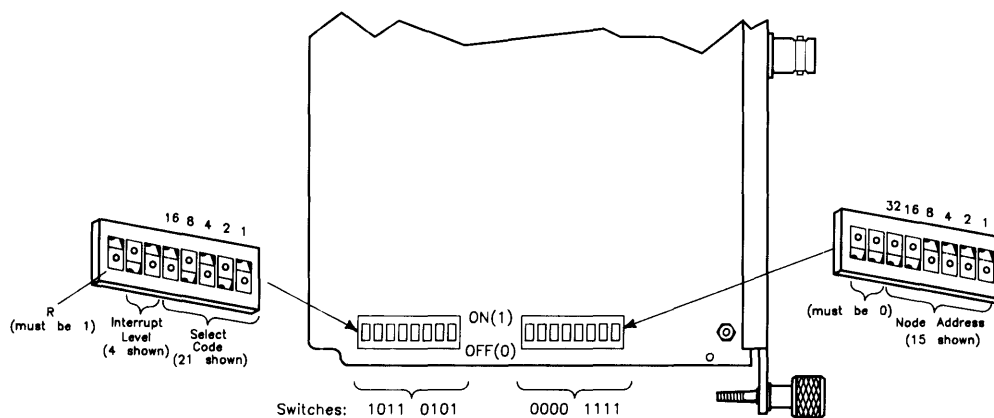

**HP 50962A SRM Coax Interface  
Workstation Configuration Switches**

<sup>1</sup> Includes HP 9000 Model 216 (9816), Model 217, Model 226 (9826), Model 236 (9836), Model 237, Model 310, and Model 320.

4. Locate and set the clusters of switches as follows:

	Value	Switch Setting
Remote (R)	true	1
Interrupt Level (INT)	4	01 <sup>2</sup>
Select Code (Sel. Code)	21 is recommended, unless you have a LAN interface whose select code has also been set to 21. To avoid a conflict, change the select code for one of these interfaces to a value other than 21.	10101
Node Address (Node Addr.)	unique address in the range 10 through 63	see table

Note that the leftmost switch in the left cluster **must be set to 1**. Note also that the leftmost two switches in the right cluster **must be set to 00**.

The following tables illustrate the correct switch settings for node addresses and select codes. You can set the switches by depressing them with a ballpoint pen or other pointed tool.

**Node Address Switch Settings**

Decimal Value	32	16	8	4	2	1	Decimal Value	32	16	8	4	2	1
10	0	0	1	0	1	0	37	1	0	0	1	0	1
11	0	0	1	0	1	1	38	1	0	0	1	1	0
12	0	0	1	1	0	0	39	1	0	0	1	1	1
13	0	0	1	1	0	1	40	1	0	1	0	0	0
14	0	0	1	1	1	0	41	1	0	1	0	0	1
15	0	0	1	1	1	1	42	1	0	1	0	1	0
16	0	1	0	0	0	0	43	1	0	1	0	1	1
17	0	1	0	0	0	1	44	1	0	1	1	0	0
18	0	1	0	0	1	0	45	1	0	1	1	0	1
19	0	1	0	0	1	1	46	1	0	1	1	1	0
20	0	1	0	1	0	0	47	1	0	1	1	1	1
21	0	1	0	1	0	1	48	1	1	0	0	0	0
22	0	1	0	1	1	0	49	1	1	0	0	0	1
23	0	1	0	1	1	1	50	1	1	0	0	1	0
24	0	1	1	0	0	0	51	1	1	0	0	1	1
25	0	1	1	0	0	1	52	1	1	0	1	0	0
26	0	1	1	0	1	0	53	1	1	0	1	0	1
27	0	1	1	0	1	1	54	1	1	0	1	1	0
28	0	1	1	1	0	0	55	1	1	0	1	1	1
29	0	1	1	1	0	1	56	1	1	1	0	0	0
30	0	1	1	1	1	0	57	1	1	1	0	0	1
31	0	1	1	1	1	1	58	1	1	1	0	1	0
32	1	0	0	0	0	0	59	1	1	1	0	1	1
33	1	0	0	0	0	1	60	1	1	1	1	0	0
34	1	0	0	0	1	0	61	1	1	1	1	0	1
35	1	0	0	0	1	1	62	1	1	1	1	1	0
36	1	0	0	1	0	0	63	1	1	1	1	1	1

<sup>2</sup> Note that the two switches governing the interrupt level do NOT follow binary numbering conventions.

### Select Code Switch Settings

Decimal Value	16	8	4	2	1
21	1	0	1	0	1
22	1	0	1	1	0
23	1	0	1	1	1
24	1	1	0	0	0
25	1	1	0	0	1
26	1	1	0	1	0
27	1	1	0	1	1
28	1	1	1	0	0
29	1	1	1	0	1
30	1	1	1	1	0
31	1	1	1	1	1

---

#### Note

Attempting to use values other than those specified in the tables could result in improper system operation.

---

## The Coax Network Connection

1. If you are using an HP 50960A SRM Coax Interface, skip to step 3.

If you are upgrading an HP 98629 Resource Management Interface with the HP 50691 Resource Management Coax Adapter for use on a coax network, attach the interface and the adapter. If the interface and adapter are not attached, do so according to the instructions which were shipped with the adapter.

2. Hold the coax adapter as shown in the illustration below and use a pointed tool to set the node address on the adapter to the **same node address** used for the resource management interface.

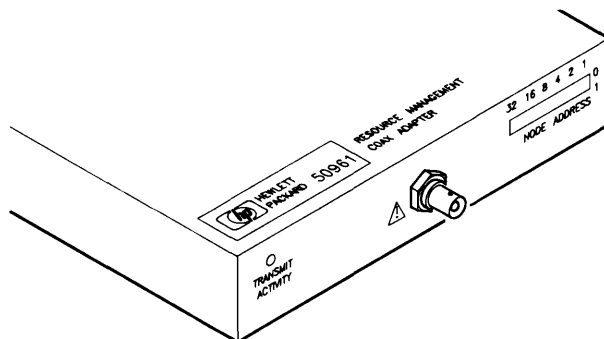

**HP 50961 Resource Management Coax Adapter**

3. Attach the corresponding node address label to the SRM interface (or to the coax adapter) where it is easily seen.
4. Turn the workstation OFF. Pick up the SRM interface by holding it firmly by its thumbscrews or coverplate. Align the board with a designated backplane slot and gently slide the interface in until the thumbscrews are lined up with the screw holes.
5. Simultaneously tighten both thumbscrews until the interface coverplate is flush with the back of the workstation.

---

**CAUTION**

AN UNTERMINATED CABLE CAN CAUSE PERMANENT DAMAGE TO HP 50961 OR 50962A COAX INTERFACE CARDS. MAKE SURE BOTH ENDS OF YOUR SRM NETWORK CABLE ARE PROPERLY TERMINATED, AND THAT ONE END IS GROUNDED. DO NOT GROUND BOTH ENDS OF THE NETWORK CABLE.

---

**Correct and Incorrect Coax Connections**

The following illustration shows the correct coax connection: the T connectors are attached to the coax interface or the coax adapter; the coax cables are attached to the T connectors; both ends of the coax network are terminated; and, one end of the link is grounded.

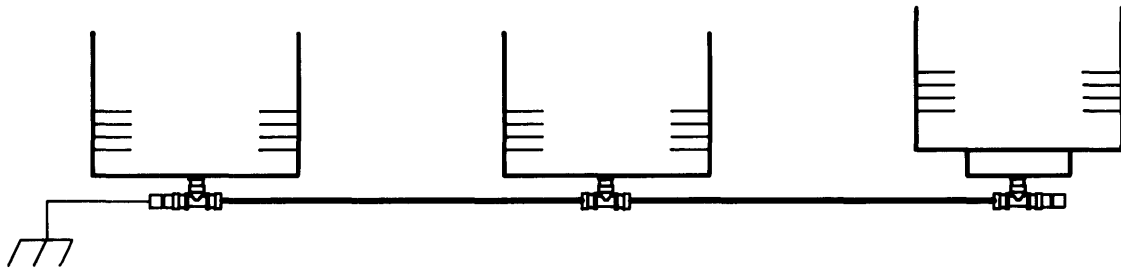

**Correct Coax Connection**

The next illustration of a coax network is incorrect because a coax cable cannot be connected directly to a coax interface or a coax adapter.

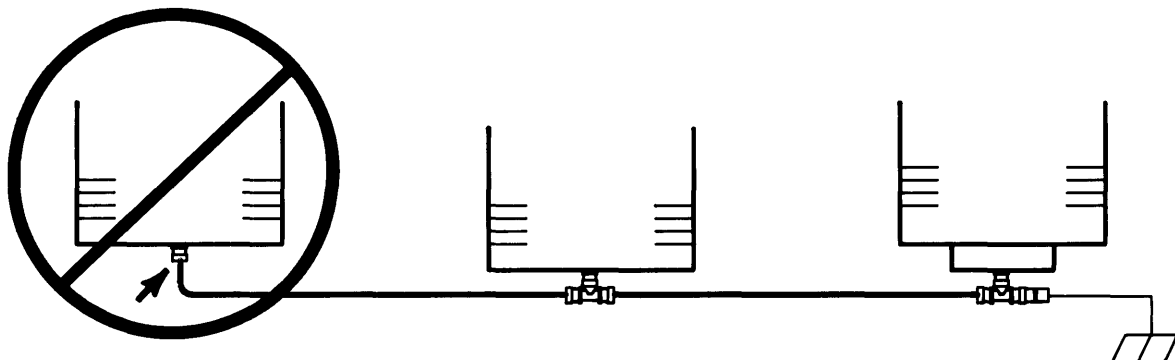

**Incorrect Coax Connection**

The next illustration of a coax network is also incorrect because you cannot use a length of coax cable between the coax interface or the coax adapter and the T connector.

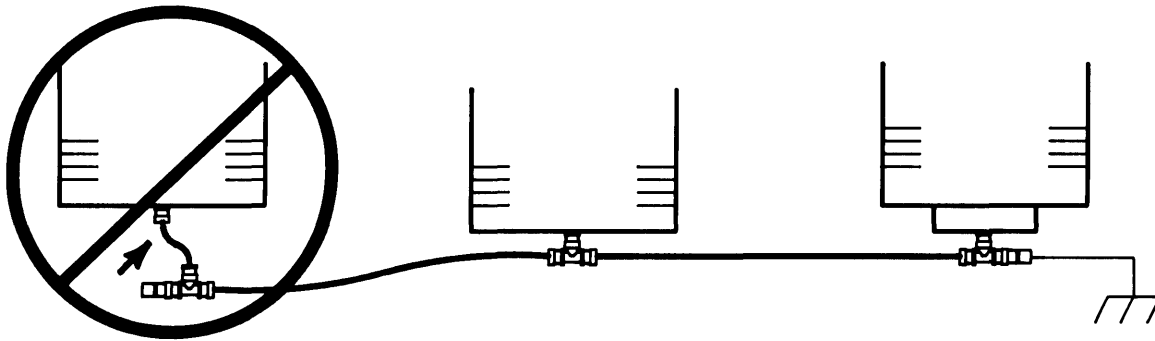

**Incorrect Coax Connection**

To assure product and personal safety, cover any exposed connectors — T connectors, barrel connectors, or terminators — on the network. Use the covers that come with the T connectors.

## Connecting the Series 200 or Series 300 Workstation to the Coax Network

1. Attach the T connector to the coax connector on the coax interface or on the coax adapter. Complete the network connection by attaching two coax cables, a cable and a terminator, or a cable and a grounded terminator. Use a short push and a clockwise twist to lock each of the connectors in place.

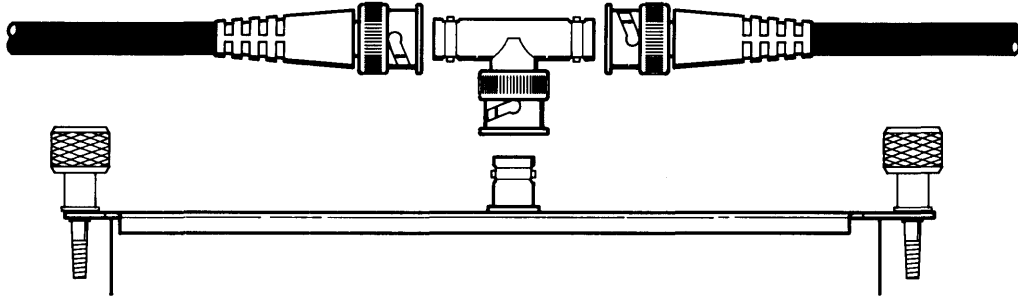

If it becomes necessary to physically disconnect the workstation from the coax network, do so by unplugging the T connector from the workstation. Leave the cables or cable and terminator connected to the T to preserve the network's continuity for other workstations and servers.

2. Cover the T connector with the insulator and snap the insulator into place.

---

### CAUTION

TO ASSURE PERSONAL AND PRODUCT SAFETY, AN INSULATING "BOOT" MUST BE USED TO COVER THE COAX T CONNECTOR.

---



3. Connect the workstation's power cord to its power socket and plug the cord into an AC power outlet.
4. Repeat "Installing Series 200 and Series 300 Workstations" for any other Series 200 or Series 300 computers used with the SRM system.
5. When you've finished installing all of the workstations, turn to the *Software Installation Manual* for installing the SRM operating system.

---

## Installing Series 500 Workstations

Series 500 workstations<sup>1</sup> communicate with the SRM system through the HP 27123A Resource Management Interface. This is true whether they are connected via the coax network configuration or the multiplexer network configuration. Individual workstations are identified to a server by the workstation's unique node address. These addresses are set by small switches on the resource management interface before it is installed in its workstation. Use your system configuration worksheets in Appendix D to record node addresses as you configure your SRM workstations.

---

### Note

The installation instructions below assume that you are using an HP 9000 Model 520 computer. If, in fact, you are using a Model 530, 540, 550, or 560, tailor the installation procedure to the hardware characteristics of your computer.

---

1. If you haven't already done so, unpack your Series 500 workstation from its shipping carton. Set up the computer according to its instructions. Make all the necessary connections for any local peripherals according to their installation instructions. Situate the computer so that the I/O interface slots on its right side (when you face the front of the machine) are accessible.
2. Turn the computer OFF.
3. To gain access to the interface card cage, place your fingertips in the groove located to the right of the display supports. Pull out and down to open the door.
4. Twist the locking screws on the interior door counterclockwise to loosen. (A small flat-blade screwdriver may be required to turn the locking screws.) Turn the screws until the door is open.
5. Carefully unpack the HP 27123A Resource Management Interface from its shipping carton, leaving it in its protective envelope. Inspect the carton and remove any additional literature.

---

<sup>1</sup> Includes HP 9000 Models 520, 530, 540, 550, and 560 (also known as 9020, 9030, 9040, 9050, and 9060, respectively).



6. Handle the interface carefully by its ejector tabs and edges only. Remove the interface from the protective envelope and place it on a dry, flat surface, oriented as shown in the diagram below.

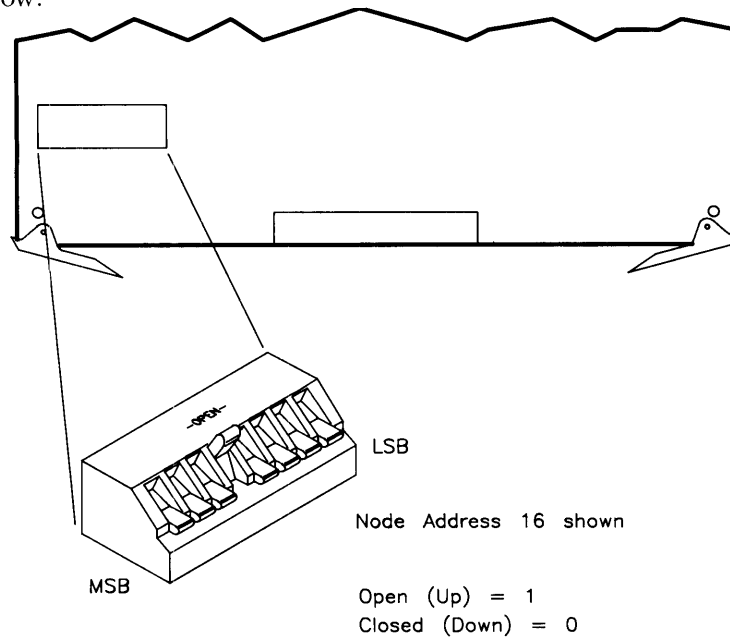

#### **HP 27123A Resource Management Interface Configuration Switches**

7. Locate the node address switches, refer to your system planning worksheets, and set a unique node address for the workstation according to the table below. Node addresses of 10 through 63 are recommended for SRM workstations. (The Series 500 resource management interface does not require setting the interrupt level or the select code. The select code is determined by which slot the board occupies.)

### Node Address Switch Settings

Decimal Value	MSB	LSB	Decimal Value	MSB	LSB
10	0000	1010	37	0010	0101
11	0000	1011	38	0010	0110
12	0000	1100	39	0010	0111
13	0000	1101	40	0010	1000
14	0000	1110	41	0010	1001
15	0000	1111	42	0010	1010
16	0001	0000	43	0010	1011
17	0001	0001	44	0010	1100
18	0001	0010	45	0010	1101
19	0001	0011	46	0010	1110
20	0001	0100	47	0010	1111
21	0001	0101	48	0011	0000
22	0001	0110	49	0011	0001
23	0001	0111	50	0011	0010
24	0001	1000	51	0011	0011
25	0001	1001	52	0011	0100
26	0001	1010	53	0011	0101
27	0001	1011	54	0011	0110
28	0001	1100	55	0011	0111
29	0001	1101	56	0011	1000
30	0001	1110	57	0011	1001
31	0001	1111	58	0011	1010
32	0010	0000	59	0011	1011
33	0010	0001	60	0011	1100
34	0010	0010	61	0011	1101
35	0010	0011	62	0011	1110
36	0010	0100	63	0011	1111

---

#### Note

Attempting to use values other than those specified in the table could result in improper system operation.

---

- Pick up the resource management interface by holding it firmly by its ejector tabs and edges. Align the board with its designated interface slot and gently insert the interface.
- Press evenly on the edge of the board with your thumbs until the board is seated.

## The Coax Network Connection

### The HP 50961 Resource Management Coax Adapter and Interface Cable

1. If the 50961-61600 interface cable and HP 50961 Resource Management Coax Adapter need to be unpacked, do so now.
2. The coax adapter as shown in the illustration and use a pointed tool to set the node address on the adapter to the **same node address** used for the resource management interface. Note the use of **six** switches on the coax adapter rather than eight as on the resource management interface. Beginning with the least significant bit (LSB) switch of the coax adapter (right-most, when held as shown) and the “LSB” in the table of node addresses in the previous section, set the node address for the coax adapter.

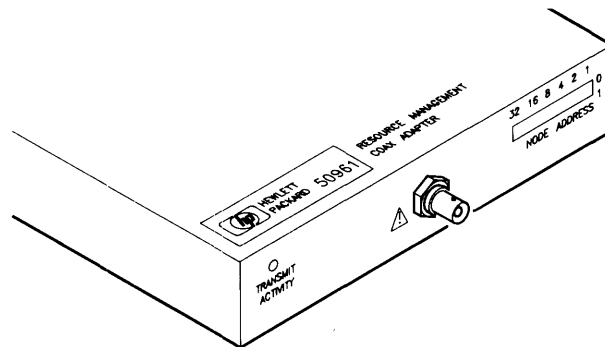

3. Attach the corresponding node address label to the coax adapter where it is easily seen.
4. Attach the end of the cable opposite the coax adapter to the connector on the edge of the installed interface and arrange for the cable to go out towards the back of the computer.

---

#### CAUTION

DUE TO THE ELECTRICAL REQUIREMENTS OF THE HP 50961 RESOURCE MANAGEMENT COAX ADAPTER, BE SURE TO USE THE INTERFACE CABLE SHIPPED WITH THE COAX ADAPTER. FAILURE TO DO SO COULD RESULT IN SYSTEM FAILURE.

---



5. Close the interior door of the computer. Push in and turn the fastening screws clockwise until tight. (A small flat-blade screwdriver may be needed.)
6. Close the outer door of the computer.

### Correct and Incorrect Coax Connections

The following illustration shows the correct coax connection: the T connectors are attached to the coax adapter, the coax cables are attached to the T connectors, both ends of the coax network are terminated, and one end of the network is grounded.

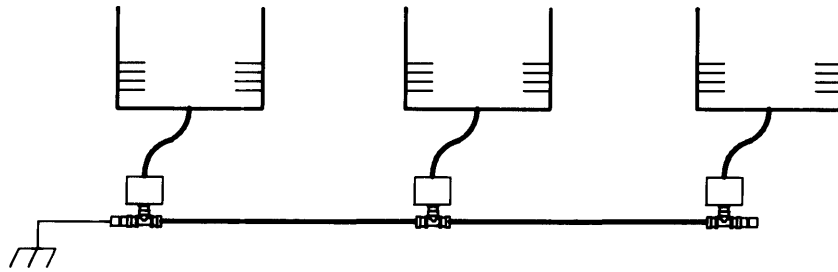

Correct Coax Connection

The next illustration of a coax network is incorrect because a coax cable cannot be connected directly to a coax adapter.

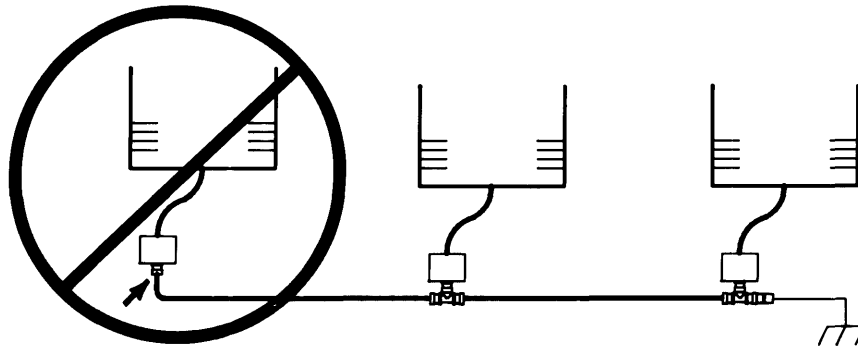

Incorrect Coax Connection

The next illustration of a coax network is also incorrect because you cannot use a length of coax cable between the coax adapter and the T connector.

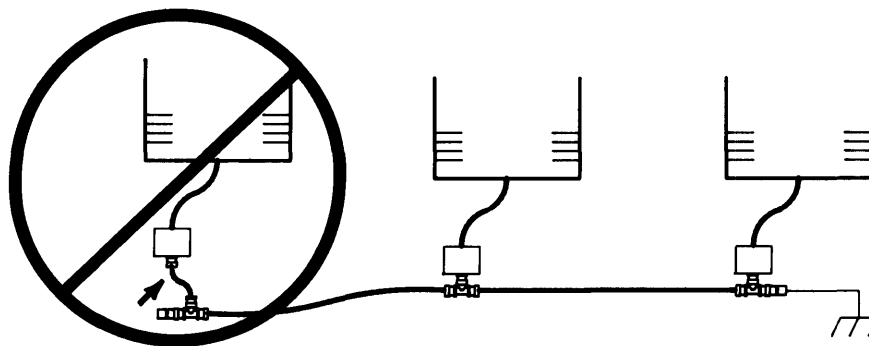

Incorrect Coax Connection

## Connecting the Series 500 Workstation to the Coax Network

1. The T connector is probably already attached to the coax adapter. Complete the network connection by attaching two coax cables, a cable and a terminator, or a cable and a grounded terminator. Use a short push and clockwise twist to lock each of the connectors in place.

If it becomes necessary to physically disconnect the workstation from the coax network, do so by unplugging the T connector from the HP 50961 Resource Management Coax Adapter. Leave the cables or cable and terminator connected to the T to preserve the network's continuity for other workstations and servers.

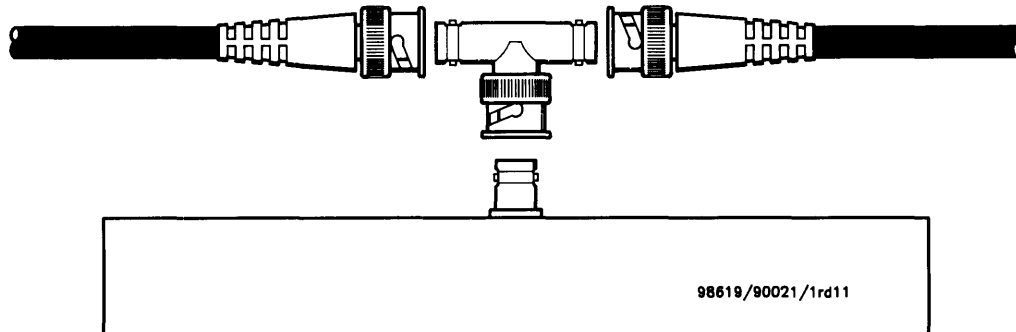

2. Cover the T connector with the insulators and snap it into place.

---

### CAUTION

TO ASSURE PERSONAL AND PRODUCT SAFETY, AN INSULATING "BOOT" MUST BE USED TO COVER THE COAX T CONNECTOR.

---



3. Connect the workstation's power cord to its power socket and plug the cord into an AC power outlet.
4. Repeat "Installing Series 500 Workstations" for any other Series 500 computers used with the SRM system.
5. When you've finished installing all the workstations, turn to the *Software Installation Manual* for installing the SRM operating system.

---

## **Installing HP Vectra PC Workstations**

To install HP Vectra PC workstations on th SRM, refer to the *HP 50963A SRM Coax Interface Installation Instructions*, shipped with the HP Vectra's SRM Coax Interface.

---

## Network Maintenance

It is recommended that you regularly inspect the integrity of the SRM network grounding, especially after a power surge or severe electrical storm. Although a node may appear to function properly, its internal surge protection could be damaged. This can lead to data collision problems on the network.

To verify the integrity of the network grounding, use the following procedure. You need an ohmmeter for the procedure.

To check each node:

1. Turn the power OFF on the server or workstation to be tested.
2. Disconnect the T-connector and coax cable from the BNC connector of the tested I/O card (such as a 50961A, 50962A, or 50963A).
3. Place one test lead of the ohmmeter to the outer conductor of the BNC connector (this is the metal connector that the T-connector fits onto). Then place the other test lead to one of the exposed mounting screws for the 50961A, or any thumbscrew on the 50962A, or the faceplate for the 50963A. There is no need to remove the I/O card from the server or workstation.
4. You should measure an infinite resistance and the ohmmeter should print OVL or OPEN to represent an open circuit. If you measure lower than 300,000 ohms, then the I/O card may have experienced electrical damage. Contact your local HP Sales or Service and return the I/O card to be repaired.

---

## Service and Repair

The Shared Resource Management system includes the server, shared peripherals, interconnecting data communication links, and user workstations. Additional peripherals can be connected to individual workstations depending on the application.

Service, troubleshooting, and repair procedures are beyond the scope of this manual. Some service information is included with selected system components, but not with all. For service and repair, most customers prefer to purchase a service contract through their HP Sales and Service Office, especially for systems that have the complexity of SRM networks. Other customers have their own service facilities and can provide their own service and repair using properly trained service personnel.

---

## Repair Philosophy

Hardware used in SRM systems requires sophisticated test equipment and facilities if repair is to be performed at the individual component level. Since this requirement is impractical for most field situations, repair usually consists of replacing the defective assembly with a new one. Some assemblies can be exchanged for a rebuilt assembly if exchange service is available for the assembly involved.

Due to high labor costs for making repairs, interfaces and other relatively low-cost items are considered throw-away assemblies when they fail. When you need service or repair parts, contact your HP Sales and Service Office for assistance.

Appendix C of this manual contains theories of operation for the SRM Coax Interface and the HP 50961 Resource Management Coax Adapter. The HP 98028A Resource Management Multiplexer, the HP 98629 Resource Management Interface, the HP 98029A Resource Management



# Appendix

# A

## Supported Hardware

The following hardware items are supported for use in their specified SRM functions.

### SRM Server

The HP 50960A is available for use as Shared Resource Management server. The HP 50960A has six accessory slots, three of which are used for I/O interfaces. Since there's space for only one HP 50962A SRM Coax Interface or one HP 98629 Resource Management Interface, the HP 50960A is typically used in a coax link configuration.

The following components are included with the server when it is ordered:

Product Number	Qty	Description
<b>HP 50960A:</b> HP 98204C Opt. 090 or 98546-66571	1	Composite Video Interface without graphics
HP 98561-66532	1	Human Interface/HP-IB w/Battery-Powered Clock
HP 50962A	1	SRM Coax Interface
HP 46020A	1	HP-HIL Keyboard (ordered separately)
HP 82913A or HP 35731B	1	Video Monitor (ordered separately)

### SRM Workstations

The following computers can be used as workstations on SRM:

- HP 9000 Series 200, 300, and 500 workstations;
- HP 9835A/B and 9845B/C desktop computers; and
- HP Vectra personal computers installed with the HP Language Processor and RAM extensions.

---

## System Software

### SRM Servers

HP 98619A operating system software is recorded on a 1/4 inch tape.

Included are the following utilities and systems:

- SRM Installation Utility
- SRM Backup/Restore Utility
- SRM Disc Check Utility
- SRM System WITH Backup/Restore
- SRM System WITHOUT Backup/Restore

### SRM Workstations

The following computers can be used as workstations in SRM systems:

- HP 9000 Series 200 and Series 300 computers with BASIC, Pascal, or HP-UX operating system;
- HP 9000 Series 500 computers with BASIC or HP-UX operating system; and
- HP Vectra PCs installed with the HP Language Processor with BASIC operating system.

---

## Power Requirements, Weights, and Clearances

Refer to your *SRM System Planning Guide* for further details concerning power requirements for your server, workstations, and peripherals. Weights and clearance specifications are also covered in the *SRM System Planning Guide*.

## Appendix

---

### Example 1 Simple SRM System Using Coax Network Configuration

#### SRM System Components

Server:	HP 50960A
Disc/Tape Drive:	HP 7946A
Printer:	HP 2934A
Plotter:	HP 7570
Workstations:	HP 9000 Model 310 (Qty: 3) HP 9000 Model 320 (Qty: 1)

**Example 1: System Map**

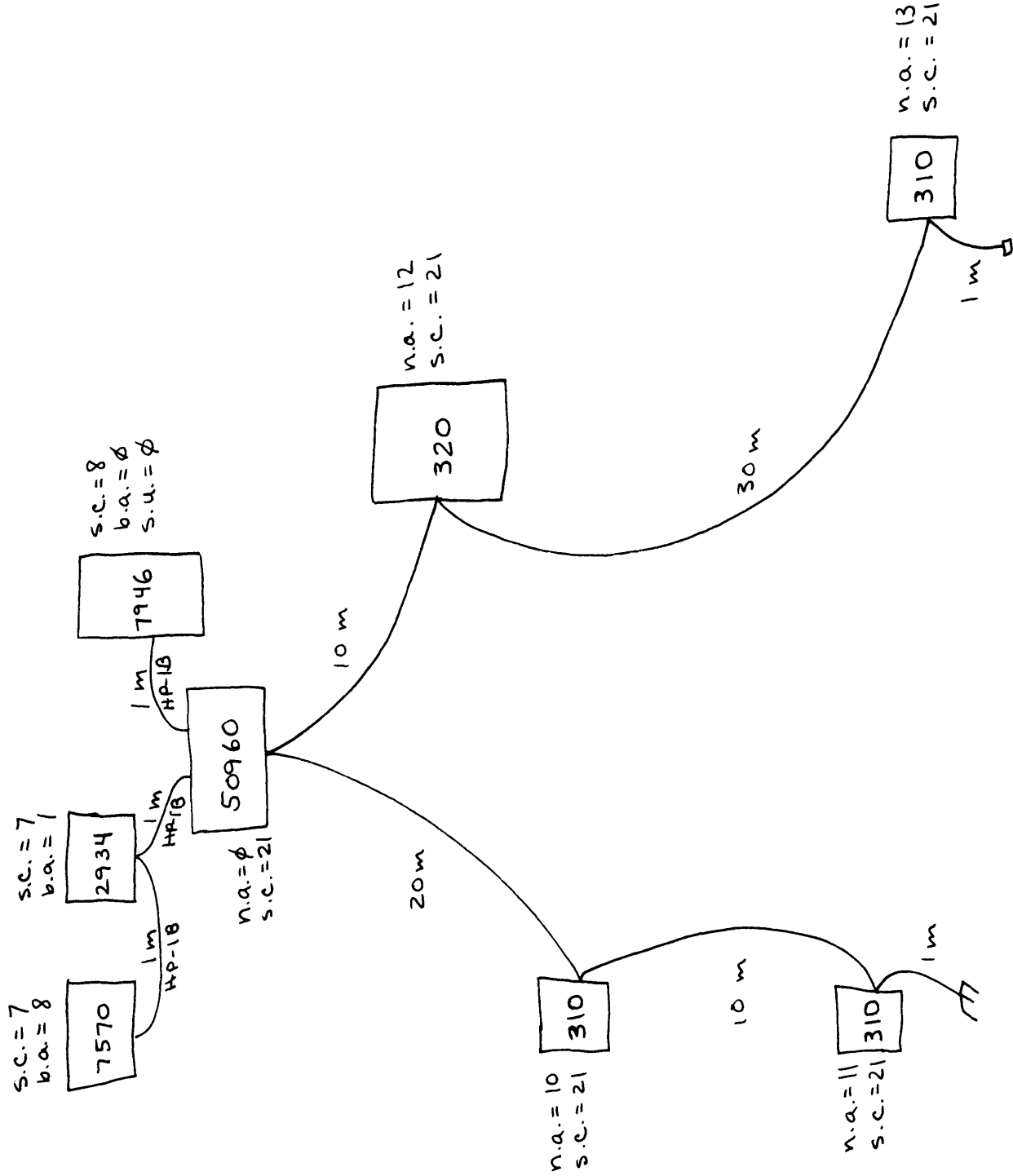



## Example 1: Worksheet for Shared Peripherals

Server Node Address\*: ϕ

### SHARED PERIPHERALS:

Printer/Plotter	Model	Interface Select Code	Bus Address <sup>1</sup>
Printer #1	2934 A	7	1
Printer #2		7	
Printer #3		7	
Printer #4		7	
Printer #5 or Plotter #1	7570	7	8
Printer #6 or Plotter #2		7	
Printer #7 or Plotter #3		7	
Printer #8 or Plotter #4		7	

<sup>1</sup> Required bus addresses: 0 thru 7 for printers only, 8 thru 29 for plotters only.

### SHARED MASS STORAGE:

Shared Disc/Tape	Model	Interface Select Code <sup>1</sup>	Bus Address <sup>2</sup>	Subunit Number
Disc/Tape	7946 A	8	ϕ	ϕ

<sup>1</sup> Select code = 8 when using HP 50960A; select code = 14 when using HP 9000 Models 200 or 226.

<sup>2</sup> Required bus addresses: 0 thru 7; lowest bus address = primary mass storage device (must be a disc).

\* Use one of these worksheets for each server in your SRM system.

---

## Example 2

### Multiple Servers/Multiple Discs Using Coax Network Configuration

#### SRM System Components

Servers: HP 50960A (Qty: 2)

Disc/Tape Drives: HP 7914P  
HP 7942A  
HP 7945A  
HP 35401

Printers: HP 2563A  
HP 2631B

Plotter: HP 7550A

Workstations: HP 9000 Model 216 (Qty: 2)  
HP 9000 Model 217 (Qty: 3)  
HP 9000 Model 226 (Qty: 1)  
HP 9000 Model 236 (Qty: 2)  
HP 9000 Model 310 (Qty: 1)  
HP 9000 Model 320 (Qty: 1)  
HP 9000 Model 520 (Qty: 2)

# Example 2: System Map

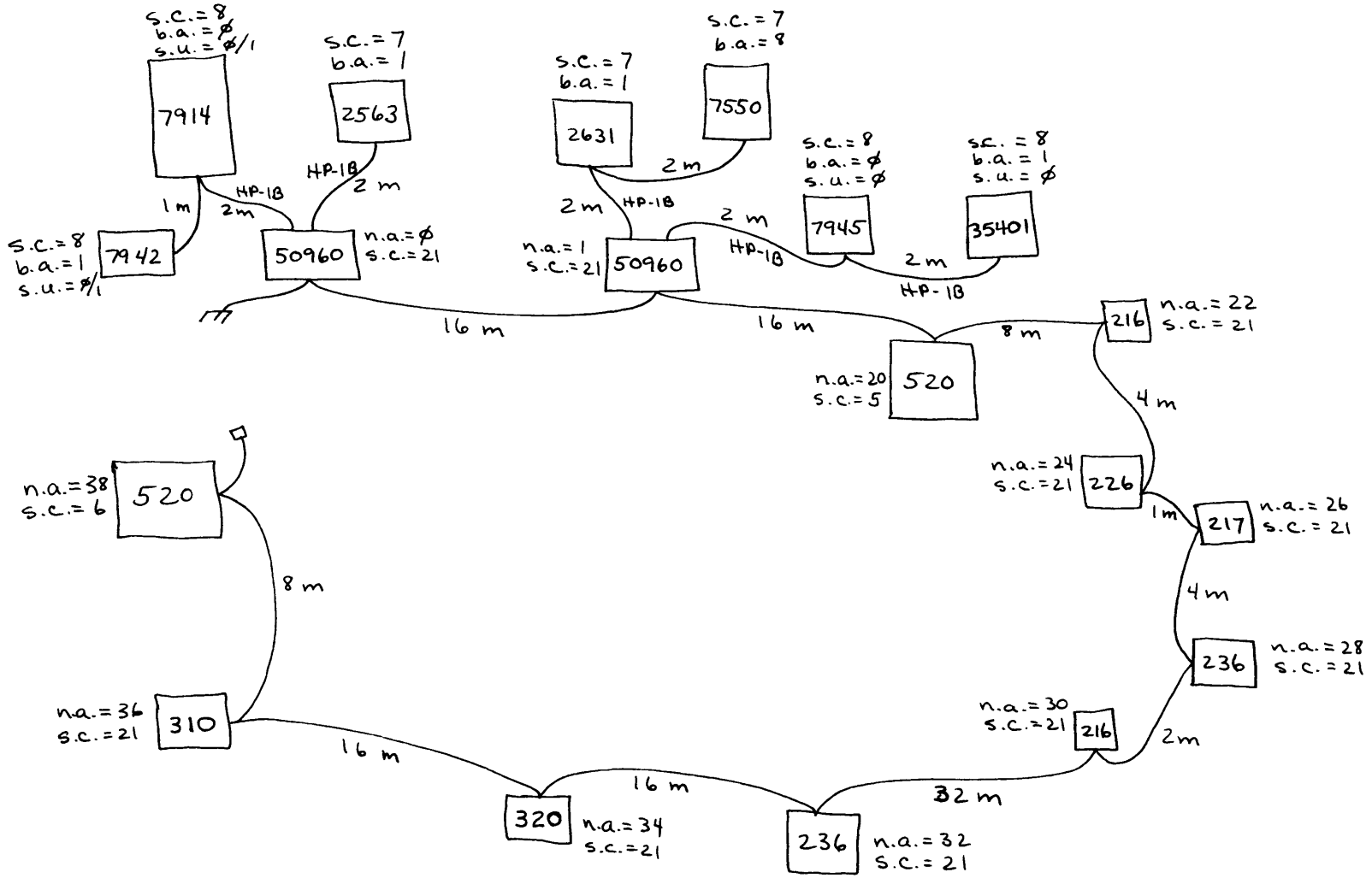





## Example 2: Worksheets for Shared Peripherals

Server Node Address\*:      $\phi$     

### SHARED PERIPHERALS:

Printer/Plotter	Model	Interface Select Code	Bus Address <sup>1</sup>
Printer #1	2563A	7	1
Printer #2		7	
Printer #3		7	
Printer #4		7	
Printer #5 or Plotter #1		7	
Printer #6 or Plotter #2		7	
Printer #7 or Plotter #3		7	
Printer #8 or Plotter #4		7	

<sup>1</sup> Required bus addresses: 0 thru 7 for printers only, 8 thru 29 for plotters only.

### SHARED MASS STORAGE:

Shared Disc/Tape	Model	Interface Select Code <sup>1</sup>	Bus Address <sup>2</sup>	Subunit Number
Disc/Tape	7914P	8	$\phi$	$\phi$ / 1
Disc/Tape	7942A	8	1	$\phi$ / 1

<sup>1</sup> Select code = 8 when using HP 50960A; select code = 14 when using HP 9000 Models 200 or 226.

<sup>2</sup> Required bus addresses: 0 thru 7; lowest bus address = primary mass storage device (must be a disc).

\* Use one of these worksheets for each server in your SRM system.

Server Node Address\*:   1  

**SHARED PERIPHERALS:**

Printer/Plotter	Model	Interface Select Code	Bus Address <sup>1</sup>
Printer #1	2631B	7	1
Printer #2		7	
Printer #3		7	
Printer #4		7	
Printer #5 or Plotter #1	7550A	7	8
Printer #6 or Plotter #2		7	
Printer #7 or Plotter #3		7	
Printer #8 or Plotter #4		7	

<sup>1</sup> Required bus addresses: 0 thru 7 for printers only, 8 thru 29 for plotters only.

**SHARED MASS STORAGE:**

Shared Disc/Tape	Model	Interface Select Code <sup>1</sup>	Bus Address <sup>2</sup>	Subunit Number
Disc	7945A	8	∅	∅
Tape	35401	8	1	∅

<sup>1</sup> Select code = 8 when using HP 50960A; select code = 14 when using HP 9000 Models 200 or 226.

<sup>2</sup> Required bus addresses: 0 thru 7; lowest bus address = primary mass storage device (must be a disc).

\* Use one of these worksheets for each server in your SRM system.



# Appendix

## HP 50961 Resource Management Coax Adapter Theory of Operation

The HP 50961 Resource Management Coax Adapter is a small module that makes it possible to use RG-58C/U coaxial cables in an SRM system. SRM servers and HP 9000 Series 200, Series 300, and Series 500 computers are connected in bus fashion using the coax adapter and coaxial cables.

Housed in a small metal box, the coax adapter has a fifty-pin connector on one end and a BNC connector on the other. A set of six switches, used for setting the node address, can be reached with a small screwdriver or pointed tool through an opening next to the BNC connector. A small light emitting diode (LED) on the BNC end of the adapter lights up when there is transmission activity.

The adapter attaches directly to an HP 98629 Resource Management Interface for SRM servers, Series 200, and Series 300 computers. It attaches to the end of the interface cable of an HP 27123A Resource Management Interface for Series 500 computers.

Taking data from the resource management interface it's plugged into, the coax adapter encodes the data and transmits it on the SRM coax link. Data transmissions from other sources on the network are decoded by the adapter and sent to the resource management interface.

The adapter block diagram below shows the relationship between the various circuit elements.

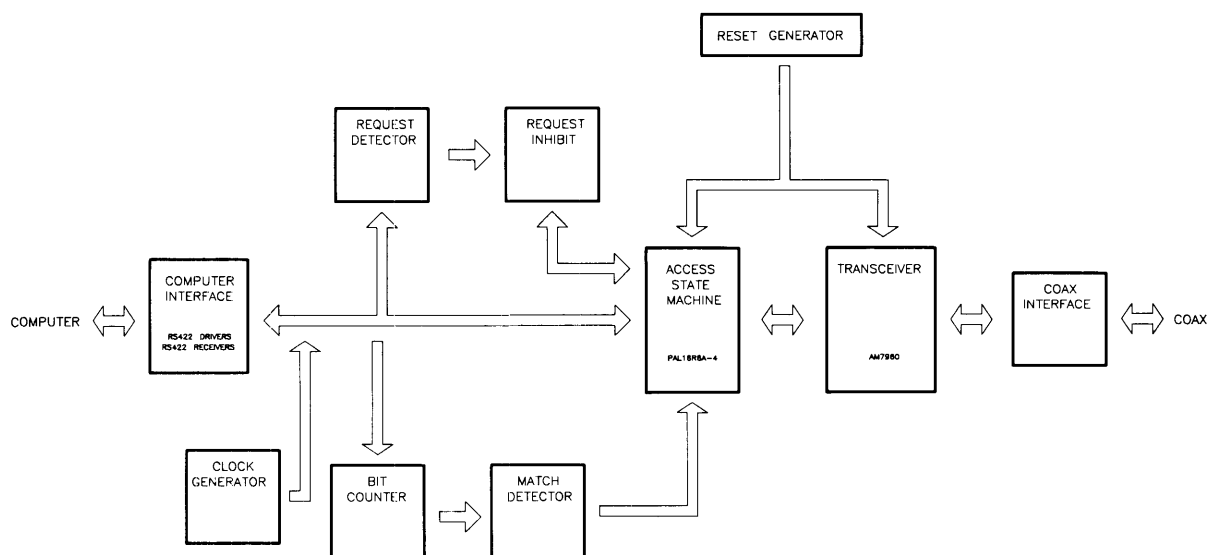

## Line Drivers and Receivers

Line drivers and receivers communicate with the resource management interface using balanced lines in both directions. The electrical characteristics adhere to the RS-422 standards. The power supply for the adapter is obtained from the interface card.

## Handshaking Between the Coax Adapter and the Resource Management Interface

As with any computer and peripheral, it is imperative that data traffic be monitored and controlled so that an orderly flow of information can be maintained. This is accomplished by the handshake activities that occur between the resource management interface and the coax adapter to which it is connected.

### Transmitting Adapter:

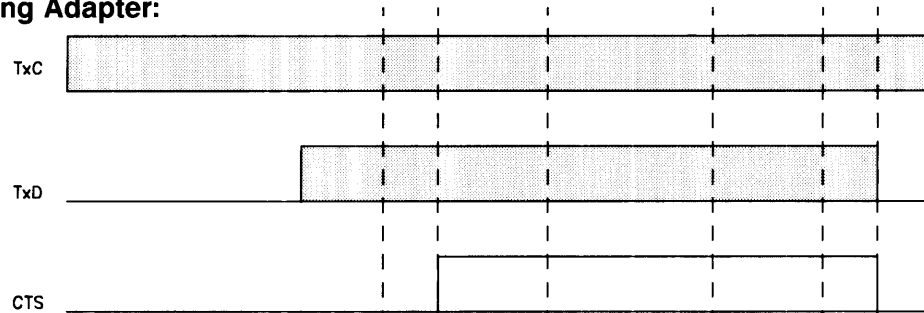

### Receiving Adapter:

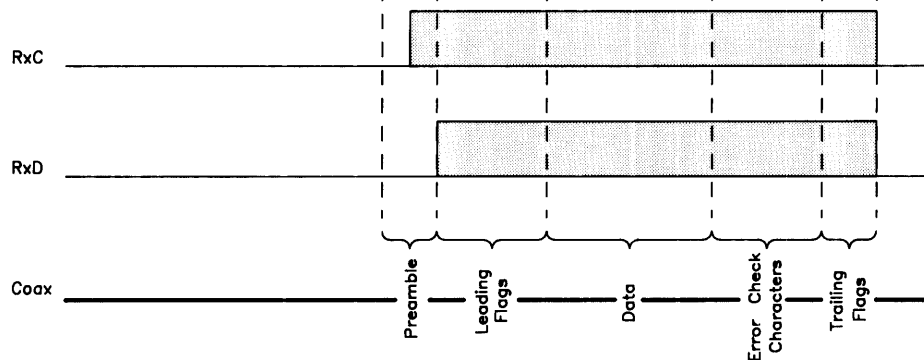

When it is powered, the adapter always sends a 700 kHz clock to the interface card on the TxC lines. This clock is derived by dividing the output from the 11.2 MHz oscillator, U5, by sixteen. When the resource management interface card has data to transmit on the coax, it begins sending SDLC (Synchronous Data Link Control) flag characters on the TxD data line. The adapter detects the presence of the flags using counter U2, and waits until the proper time for the transmission of the packet. At this point the adapter transmits a preamble on the coax from which the other modules on the coax extract the clock for the data packet.

When the preamble has been sent, the CTS line from the adapter to the interface is activated. All data from the interface is encoded and transmitted on the coax by the adapter until the transmission is complete. The end of transmission is determined by the detection of eight successive bits with no zeros. Again the counter U2 will detect the end of message.

When a message is transmitted on the coax, the adapter will decode the contents of the message and send both the serial data and the corresponding clock back to the interface on the RxD and RxC lines.

## **Coax Transceiver**

The AM7960 transceiver integrated circuit, U6, is used to interface to the coax media. This chip provides the transmit clock by dividing the oscillator output by sixteen. The coax interface is transformer-coupled through T1 to the coax media.

The communication on the network is very different than other coax networks. Signal levels, access methods, packet formats, and message timing are incompatible with all other available networks.

## **Coax Access State Machine**

Access to the coax network is time-shared among all functioning adapters so no contention can exist between potential transmissions. When a message transmission is requested by the interface card, a state machine in the adapter determines when the message will actually be transmitted on the coax. Fourteen-bit counter, U8, is used by the state machine to count bit times since the last transmission. Eight-bit comparator, U9, will signal the state machine when the transmit slot for the adapter has been reached. The state machine is implemented with Programmed Array Logic (PAL), U7, which is programmed to coordinate transmissions on the coax media.

## **Reset**

The adapter contains power supply decoupling capacitors and provides a power-on reset function. Both the access PAL and the AM7960 chip are initialized to a known state whenever the power supply drops below four volts.

---

# HP 50962A SRM Coax Interface

## Theory of Operation

The HP 50962A SRM Coax Interface is used in SRM servers and Series 200 and Series 300 workstations. It handles information transfers between workstations and servers that are connected together in a coax network configuration. The HP 50962A combines the functions of the HP 98629 Resource Management Interface and the HP 50961 Resource Management Coax Adapter.

The HP 50962A SRM Coax Interface performs the following functions:

- accepts outbound data from the workstation or server operating system;
- assembles outbound data into data packets with the proper routing information included in each packet;
- gains access to the coax network, and then encodes and transmits the data packets on the coax network;
- recognizes and decodes incoming packets, and accepts message packets that have the proper routing information (proper node address);
- assembles decoded message packets that have the proper routing information (proper node address) and responds to them directly or transfers them to the operating system;
- transfers assembled packets to the workstation or server operating system or other destination level.

The HP 50962A consists of a DIO interface, hardware registers, shared RAM, a microprocessor, ROM, two banks of eight switches, a serial I/O communications chip, a transceiver, a coax interface, and network management control hardware. It also has a small light emitting diode (LED) on the back of the interface card that lights when data transmission occurs.

### The DIO Interface

The HP 50962A uses a hundred-pin edge connector to connect to the workstation or server in which it resides. This physical connector is part of the DIO interface through which the workstation or server communicates with the HP 50962A. The DIO interface allows the workstation or server to control the HP 50962A interface by reading status registers, writing control registers, reading control blocks and data blocks from shared memory, and writing control blocks and data blocks to shared memory on the interface card.

### The Microprocessor

A microprocessor on the HP 50962A SRM Coax Interface monitors the hardware registers and shared RAM for control and data packets from the workstation or server. It also monitors and controls the activity of the serial I/O communications chip. The microprocessor takes its instructions from read-only memory (ROM) on the HP 50962A interface.



## **The Switches**

Of the two switch banks on the HP 50962A, one bank is used to set the select code and hardware interrupt level of the interface card. This bank of switches functions identically as a similar bank of switches on the HP 98629 Resource Management Interface. The other bank of eight switches on the HP 50962A combine the functions of the HP 98629 node address switches (labeled “DEFAULTS” on the board) and the HP 50961 “NODE ADDRESS” switches. This second bank of switches selects the SRM system node address for the workstation or server as well as being used in accessing the coax link. These node address switches are read by the HP 50962A’s microprocessor during power-up and after a hard reset.

## **The Serial I/O Communications Chip**

The serial I/O communications chip on the HP 50962A interface is responsible for taking byte-wide data from the microprocessor and converting it into a serial bit stream using a protocol similar to SDLC. It then sends this bit stream to the coax transceiver for transmission onto the coax. The serial I/O communications chip also receives serial data from the coax transceiver and converts this serial data into byte-wide data. This chip is also responsible for CRC generation on outgoing data and error detection on incoming data.

## **The Coax Transceiver and Coax Interface**

An AM7960 integrated transceiver takes serial data from the serial I/O communications chip and encodes it for transmission onto the coax. The transceiver sends the encoded data onto the coax through a coax interface which consists of a transformer, ESD/RFI protection circuitry, and a BNC connector. The coax transceiver also receives data transmissions through the coax interface. Upon receiving a data transmission, the coax transceiver does clock recovery and decoding on the transmission. The clock and data are then sent by the coax transceiver to the serial communications chip.

## **The Network Management Control Hardware**

Access to the coax network is time-shared among all functioning interfaces or adapters so no contention can exist between potential transmissions. When a message transmission is requested by the HP 50962A’s microprocessor, a state machine in the interface determines when the message will actually be transmitted on the coax.



# Appendix

---

## Instructions for Using the Worksheets

The following pages consist of server backplane diagrams and system configuration worksheets. They are intended to be used as an aid when planning and installing your SRM system. If necessary for larger or more complicated SRM systems, you may wish to photocopy extra sets of these worksheets.

The backplane diagrams illustrate each server's requirements for I/O interfaces used with the SRM and a logical order for inserting them in the server's backplane. It may be helpful to write on this diagram, recording the select code of each resource management interface installed in the server.

One of the worksheets provides space for recording various pieces of information about the workstations and servers and shows the relationship between the workstations and the servers to which they are connected. You can also record information about the workstation itself, such as who the primary user is, the number of a phone nearby, the workstation model number, and where the workstation is located.

The other worksheet allows you to record the model numbers, interface select codes, device bus addresses, and subunit numbers (for mass storage devices) for the shared peripherals in the SRM system. You should also write down the node address of the server they are connected to if more than one server is used in the system.

For examples on how to use these worksheets, turn to Appendix B.



Server Node Address\*: \_\_\_\_\_

**SHARED PERIPHERALS:**

Printer/Plotter	Model	Interface Select Code	Bus Address <sup>1</sup>
Printer #1		7	
Printer #2		7	
Printer #3		7	
Printer #4		7	
Printer #5 or Plotter #1		7	
Printer #6 or Plotter #2		7	
Printer #7 or Plotter #3		7	
Printer #8 or Plotter #4		7	

<sup>1</sup> Required bus addresses: 0 thru 7 for printers only, 8 thru 29 for plotters only.

**SHARED MASS STORAGE:**

Shared Disc/Tape	Model	Interface Select Code <sup>1</sup>	Bus Address <sup>2</sup>	Subunit Number

<sup>1</sup> Select Code = 8 when using HP 50960A; select code = 14 when using HP 9000 Models 200 or 226.

<sup>2</sup> Required bus addresses: 0 thru 7; lowest bus address = primary mass storage device (must be a disc).

\* Use one of these worksheets for each server in your SRM system.



## The Multiplexer Network

The following information applies only to SRM systems with already installed multiplexer network configurations. Multiplexer network configurations are no longer available and have been replaced by coax network configurations.

Communication on the SRM is achieved through either or both of two cabling schemes:

- the coax network configuration; and
- the multiplexer network configuration.

The two configurations are functionally identical and can coexist on the same SRM. Coax network configurations must be used if you want to expand a multiplexer network configuration.

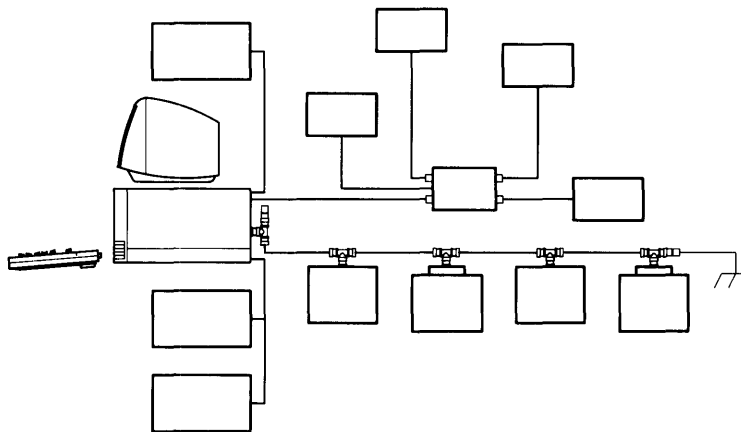

### Multiplexer Network Configuration

The multiplexer network configuration uses the HP 98028A Resource Management Multiplexer, and HP 97061 cables. Each multiplexer can support up to four workstations, one per port. The multiplexer's fifth port must connect to a dedicated resource management interface in the SRM server.

The HP 98028A Resource Management Multiplexer obtains operating power from the Series 200, Series 300, or Series 500 resource management interface to which the multiplexer is connected by its built-in power/data cable.

Series 200 workstations can power multiplexers as follows:

- Model 216 cannot power multiplexers.
- Models 217, 226, and 236 can each power up to two multiplexers, provided no power is being supplied to any external devices by another interface in the same computer. If this is the case, only one multiplexer can be powered by a Model 226 or 236 workstation.
- Model 237 can power up to seven multiplexers, provided no power is being supplied to any external devices by other interfaces in the same computer.
- Model 220 can power up to five multiplexers, provided no power is being supplied to any other external devices by other interfaces in the same computer. For each external device being supplied power by the Model 200, reduce by one the number of multiplexers receiving power from the same Model 220.

Series 300 workstations can power up to three multiplexers, provided no power is being supplied to any external devices by other interfaces in the same computer.

Series 500 workstations can power up to two multiplexers each.

HP 9835 and HP 9845 desktop computers cannot supply power to a multiplexer. Note that HP 9835/9845 computers can only be used on a multiplexer network configuration.

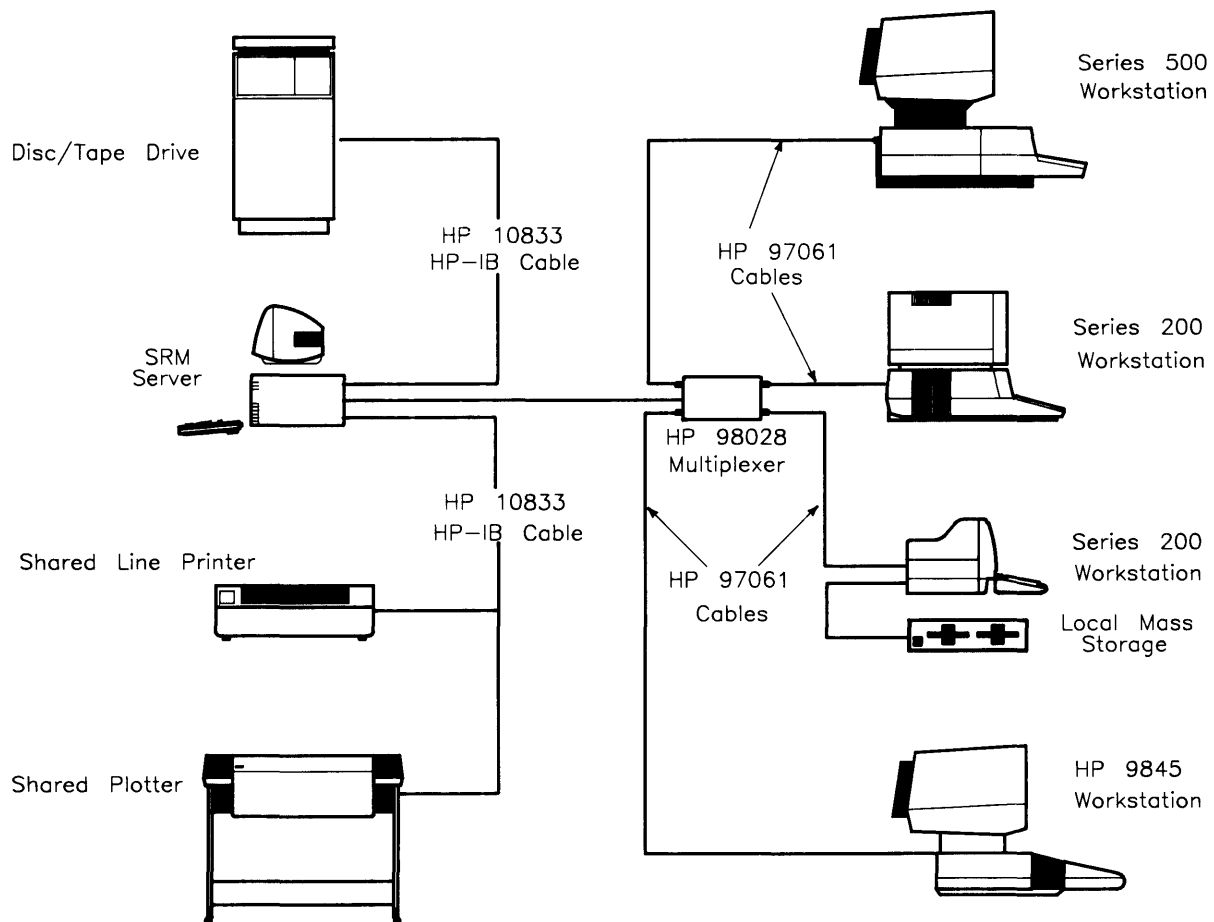

**Example of a Small Resource Management System  
Using the Multiplexer Network**



## Network Configuration Differences and Compatibilities

The HP 50960A server uses the coax network configuration because the server backplane arrangement limits the server to either one HP 50962A SRM Coax Interface or one HP 98629 Resource Management Interface. The coax network configuration allows all workstations and servers to be connected in bus fashion over greater distances than the multiplexer network configuration. An HP 9888A Bus Expander can be used if additional interface slots are needed.

Each 98629A or 27123A resource management interface can communicate with up to four workstations on a multiplexer network configuration since each multiplexer has only five ports, one of which must be connected to the SRM server. Therefore, since an HP 98629 Resource Management Interface with a unique select code must be added to the server each time the number of workstations required goes over a multiple of four.

In terms of software, the two network configurations are completely compatible and can coexist on the same SRM server. Also, the HP 27123, HP 97601A, HP 98028A, and the HP 98629 products are no longer available. However, the coax network configuration has replaced the multiplexer network configuration for new network installations.

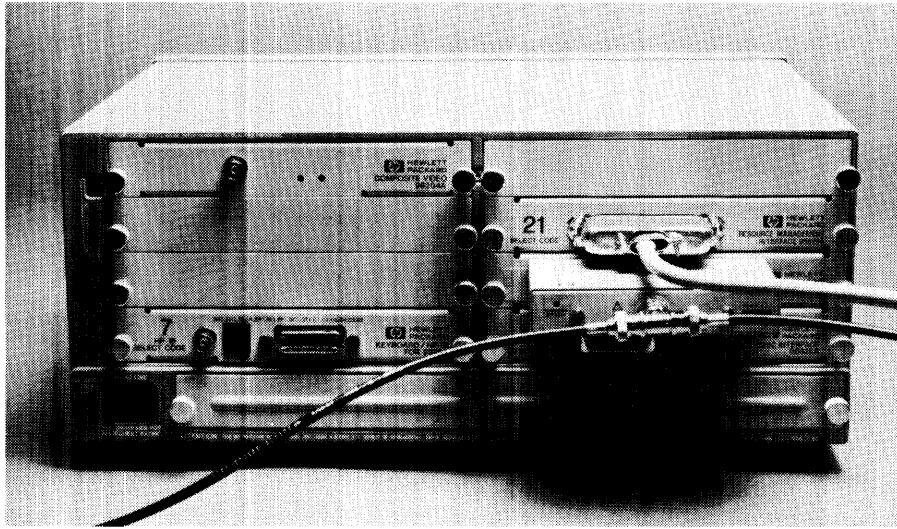

Coexistence of Coax and Multiplexer Network Configurations

---

## Example: Multiple Servers/Multiple Networks

The following example shows coax and multiplexer network configurations on the same SRM system.

SRM system components:

Servers:	HP 9000 Model 220 (Qty: 3)
Disc/Tape Drives:	HP 7908P HP 7946A (Qty: 2)
Printer:	HP 2631B HP 2608A HP 2563A (Qty: 2)
Plotters	HP 7550A HP 7585A (Qty: 2)
Workstations	HP 9000 Model 216 (Qty: 3) HP 9000 Model 217 (Qty: 1) HP 9000 Model 236 (Qty: 1) HP 9000 Model 520 (Qty: 3)

# Example: System Map

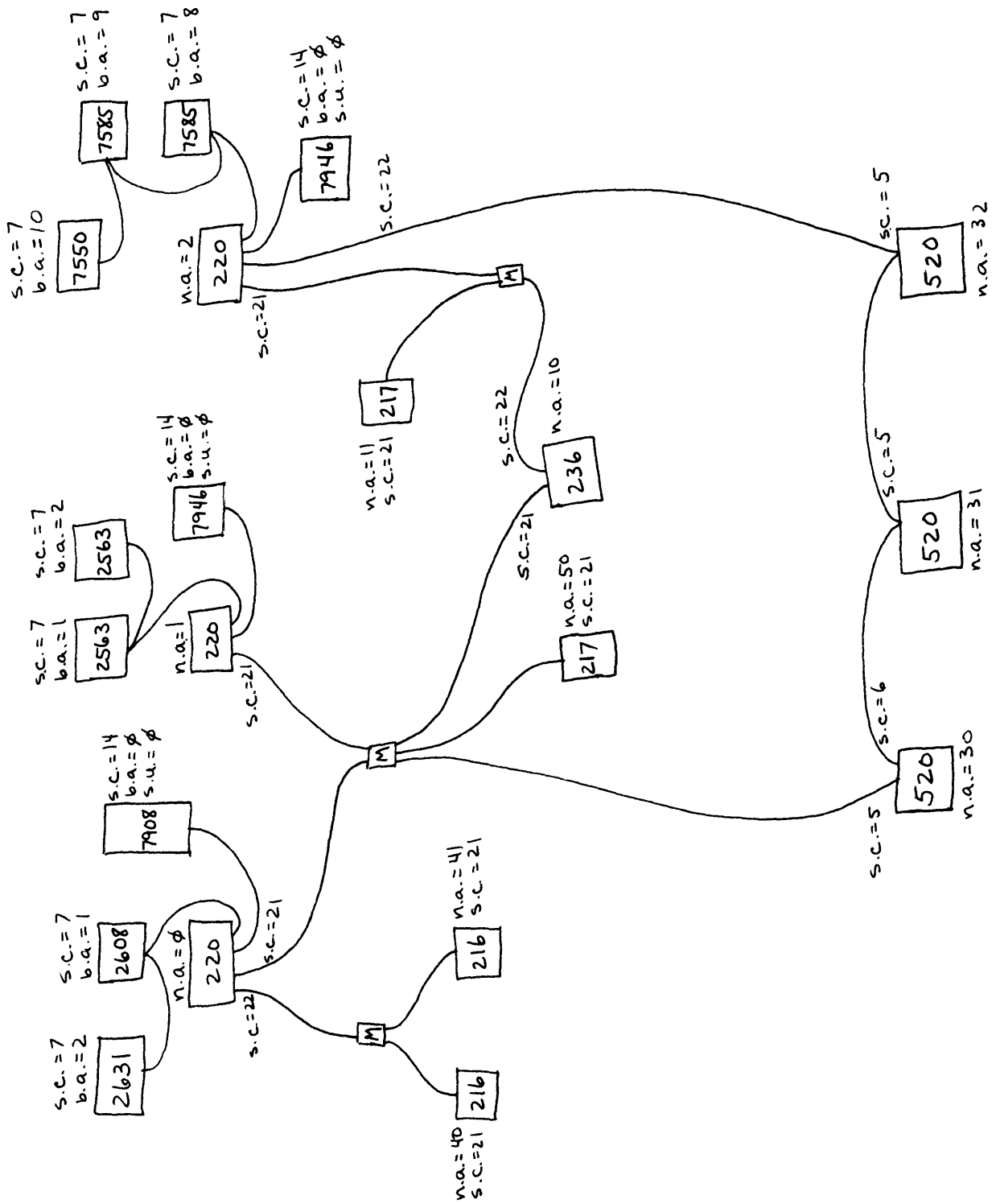

WORKSTATIONS:				CONNECTED TO SERVERS <sup>1</sup> :					
User's Name	User's Phone Number	Workstation		Workstation		SRM Interface Select Code of Server at			
		Location	Type	Select Code <sup>2</sup>	Node Address <sup>3</sup>	Node Address 0	Node Address 1	Node Address 2	Node Address 3
Carolyn		Mktg	236	21	10	21	21		
			(same)	22	10			21	
Dave		Mktg	217	21	11			21	
Harold		Admin.	520	5	30	21	21		
			(same)	6	30			22	
Bill		Advertis.	520	5	31			22	
Jean		Advertis.	520	5	32			22	
Joe		Acctg	216	21	40	22			
Sarah		Acctg	216	21	41	22			
Keith		Personnel	217	21	50	21	21		

<sup>1</sup> Recommended server select codes: 21, ..., 31.  
<sup>2</sup> Recommended workstation select codes: **Series 200/300** – 21; **Series 500** — corresponds to interface slot. Required select code for **9835/45** — 5.  
<sup>3</sup> Recommended workstation node addresses: 10, ..., 63.

Example: Worksheet for Workstations and Servers

## Example: Worksheets for Shared Peripherals

Server Node Address\*:      $\phi$     

### SHARED PERIPHERALS:

Printer/Plotter	Model	Interface Select Code	Bus Address <sup>1</sup>
Printer #1	2608A	7	1
Printer #2	2631B	7	2
Printer #3		7	
Printer #4		7	
Printer #5 or Plotter #1		7	
Printer #6 or Plotter #2		7	
Printer #7 or Plotter #3		7	
Printer #8 or Plotter #4		7	

<sup>1</sup> Required bus addresses: 0 thru 7 for printers only, 8 thru 29 for plotters only.

### SHARED MASS STORAGE:

Shared Disc/Tape	Model	Interface Select Code <sup>1</sup>	Bus Address <sup>2</sup>	Subunit Number
Disc/Tape	7908P	14	$\phi$	$\phi$

<sup>1</sup> Select code = 8 when using HP 50960A; select code = 14 when using HP 9000 Models 200 or 226.

<sup>2</sup> Required bus addresses: 0 thru 7; lowest bus address = primary mass storage device (must be a disc).

\* Use one of these worksheets for each server in your SRM system.

## Example: Worksheets for Shared Peripherals

Server Node Address\*:   1  

### SHARED PERIPHERALS:

Printer/Plotter	Model	Interface Select Code	Bus Address <sup>1</sup>
Printer #1	2563A	7	1
Printer #2	2563A	7	2
Printer #3		7	
Printer #4		7	
Printer #5 or Flotter #1		7	
Printer #6 or Plotter #2		7	
Printer #7 or Plotter #3		7	
Printer #8 or Plotter #4		7	

<sup>1</sup> Required bus addresses: 0 thru 7 for printers only, 8 thru 29 for plotters only.

### SHARED MASS STORAGE:

Shared Disc/Tape	Model	Interface Select Code <sup>1</sup>	Bus Address <sup>2</sup>	Subunit Number
Disc/Tape	7946A	14	∅	∅

<sup>1</sup> Select code = 8 when using HP 50960A; select code = 14 when using HP 9000 Models 200 or 226.

<sup>2</sup> Required bus addresses: 0 thru 7; lowest bus address = primary mass storage device (must be a disc).

\* Use one of these worksheets for each server in your SRM system.

## Example: Worksheets for Shared Peripherals

Server Node Address\*: 2

### SHARED PERIPHERALS:

Printer/Plotter	Model	Interface Select Code	Bus Address <sup>1</sup>
Printer #1		7	
Printer #2		7	
Printer #3		7	
Printer #4		7	
Printer #5 or Plotter #1	7585A	7	8
Printer #6 or Plotter #2	7585A	7	9
Printer #7 or Plotter #3	7550A	7	10
Printer #8 or Plotter #4		7	

<sup>1</sup> Required bus addresses: 0 thru 7 for printers only, 8 thru 29 for plotters only.

### SHARED MASS STORAGE:

Shared Disc/Tape	Model	Interface Select Code <sup>1</sup>	Bus Address <sup>2</sup>	Subunit Number
Disc/Tape	7946A	14	∅	∅

<sup>1</sup> Select code = 8 when using HP 50960A; select code = 14 when using HP 9000 Models 200 or 226.

<sup>2</sup> Required bus addresses: 0 thru 7; lowest bus address = primary mass storage device (must be a disc).

\* Use one of these worksheets for each server in your SRM system.

# HP 98028A Resource Management Multiplexer Theory of Operation

The HP 98028A Resource Management Multiplexer performs the switching and electrical isolation functions that enable nodes in the network to communicate. All multiplexer ports are electrically isolated from each other. Isolated grounds and power for each port's drivers and receivers prevent ground loops and related noise problems. The multiplexer draws electrical power through the short cable that is permanently attached to the multiplexer housing. The HP 98629 and the HP 27123A Resource Management Interfaces are each electrically configured to supply power to the multiplexer. Power cannot be supplied from an HP 9835A/B or an HP 9845B/C through the HP 98029A Resource Management Interface. The number of multiplexers receiving power from servers or workstations varies from model to model. See the "Multiplexer Network Configuration" section of this Appendix for the restrictions.

Here is a multiplexer block diagram that shows the relationship between the various circuit elements:

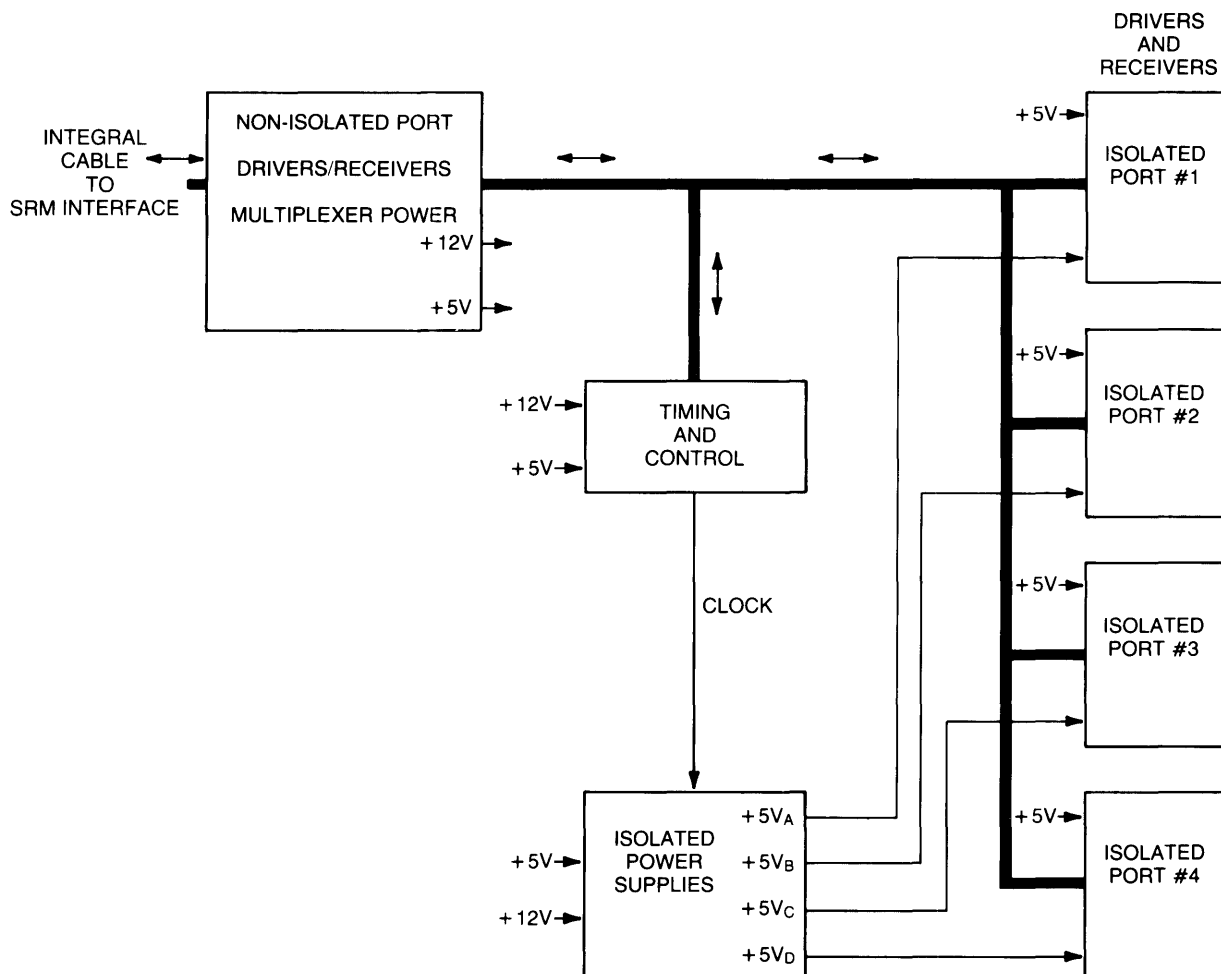

Multiplexer Block Diagram



## **Power Supplies and Port Isolation**

The multiplexer has a self-contained DC-to-DC converter that chops the incoming power from the resource management interface and converts it to AC power. The multiplexer then uses a transformer to provide four isolated power sources for the drivers and receivers that connect to remote nodes through HP 97601 cables. Opto-isolators are used to pass signals across the isolation barriers between ports.

## **Line Drivers and Receivers**

The line drivers and receivers communicate with resource management interfaces using balanced lines in both directions. The electrical characteristics are similar in some respects to EIA RS-422 standards. The four isolated ports are electrically separated from each other and the non-isolated port. There is no DC electrical continuity between one port and any other port including signal lines, power, and grounds. This isolation eliminates the potential ground-loop hazards that may arise when connecting computers together through long interconnecting cables.

## **Switching and Control Circuit**

The switching and control circuit determines the direction of data flow through the multiplexer and maintains proper timing between participating computers in the network. The switching and control circuit uses the internal 700 kHz clock oscillator to generate the timing signals sent to participating interfaces for controlling data transmission.

The term multiplexer is somewhat inaccurate. The switching and control circuit more closely resembles a digital rotary switch with five ports. Data input is taken from one port at a time in a rotary sequence. As the data arrives, it is sent out on all five ports in a “broadcast” fashion. When the data transmission from the first port is finished, the second input port is selected, and so forth until all ports have been sequenced. The process is then repeated, again beginning with the first port.

To maximize multi-user access to the network, data is handled in packets using a format similar to standard SDLC (Synchronous Data Link Control) protocol. Each participating computer is allowed to transmit one packet of data after which it must wait until all other ports have been serviced before it can send the next packet. Since the data packet includes source and destination information, it is unnecessary for the multiplexer to interpret routings. The task of identifying data destinations is left to the computer interfaces in the network.

As each interface receives data packets from the multiplexer, the interface decodes that packet destination node address. If the packet destination address does not match the programmed interface node address, the packet is ignored. If the address matches the interface node address, the interface accepts the packet and notifies the computer of its arrival.

## Handshaking Between the Multiplexer and Interfaces

As with any computer and peripheral, it is imperative that data traffic be monitored and controlled so that an orderly flow of information can be maintained. This is accomplished by the handshake activities that occur between the multiplexer and the resource management connected to the multiplexer.

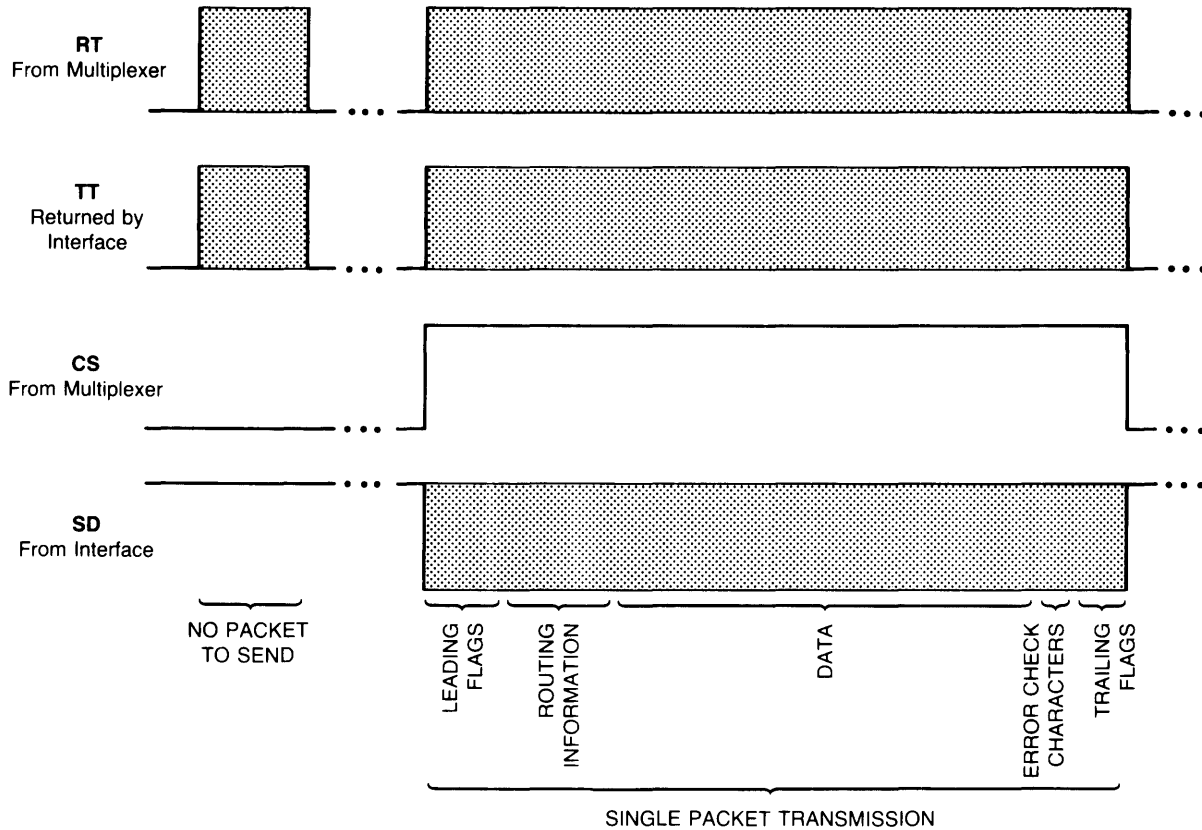

**Multiplexer-Interface Handshake Timing**

As indicated in the timing diagram, when the multiplexer polls an interface, the multiplexer sends 16 clock cycles (approximately 23 microseconds) on the RT (Receive Timing) line, then sets the CS (Clear-to-Send) if the interface responds to the clock. Note that all lines are actually differential pairs. As soon as the interface receives the RT clock signal, it returns the clock on its TT (Terminal Transmit Timing) output. If the selected interface has data to send, it immediately starts sending the SDLC flag characters on its SD (Send Data) output, indicating the start of a frame (packet). If there is no data to send, the SD output remains idle. When there is no SD response, the multiplexer switches to the next port at the end of the 16 clock cycles.

If the selected interface has a packet ready, the interface responds by sending SDLC flag characters on SD. If the multiplexer detects activity on SD and TT, it sends CS, then maintains the open channel to the interface by holding CS and RT active until the transmission is completed. The end of a transmission is determined by the detection of eight successive bits with no zeroes. U12 and U9 are used to detect eight successive ones received. U12 is an 8-bit shift register that holds the most recent data. If all outputs are low (indicating eight ones received), CS is cleared by U9, and the controller switches to the next port.

As data arrives on the SD line, the data is sent directly to all RD (Receive Data) outputs. RT and CS are inhibited to the inactive input ports by the tri-state enable lines driven by U13. If CS is inactive on a given port, the interface on that port is expected to monitor incoming data and not attempt to transmit. However, if an interface should inadvertently transmit, the inputs on that port are also disabled by the same line that disables RT and CS, thus preventing data collisions.

## **Analog Circuits**

Line impedances from the multiplexer to the interface are nominally 100 ohms. The output drivers are designed to feed a 100-ohm load. The resistor/diode and series resistor pair at each input form an approximately 100-ohm termination for the load end of the line, maintaining a balanced line with minimal reflections.

The rest of the circuitry is relatively straight-forward. The +12-volt supply is used to provide +5-volt power to the isolated ports. Opto-isolators provide signal passage across isolated boundaries. U14 is a frequency divider used to generate the clock signals for timing and power-supply switching.

---

# **HP 98629 Resource Management Interface**

## **Theory of Operation**

The HP 98629 Resource Management Interface handles all information between the computer it resides in and one or more remote computers in the system. The interface performs the following functions:

- assembles outbound data transmissions into data packets with proper routing information included in each packet.
- recognizes timing signals from an HP 50961 Resource Management Coax Adapter or from an HP 98028A Resource Management Multiplexer and transmits message packets at the appropriate time, thus avoiding data collisions.
- recognizes information and accepts message packets that have the proper node address; ignores messages containing other node addresses.
- decodes incoming message packets and transfers them to the local computer operating system or other specified destination.
- provides electrical power to a coax adapter, or to a multiplexer if the multiplexer power cable is connected to the interface.

## Data Transmission on a Multiplexer Network Configuration

When data is being sent by the interface, the following sequence of events occurs:

- Data messages are sent to the interface by the local operating system.
- The interface assembles the information into packets and adds routing information.
- The multiplexer sequentially interrogates each interface. When the appropriate timing signals are received from the multiplexer, the interface transmits a message packet.
- The multiplexer broadcasts the message packet to all of the interfaces that are connected to the multiplexer.
- After the packet is transmitted, the multiplexer switches to the next interface. Timing and Clear-to-Send lines to the interface are disabled. If multiple packets are being sent, the interface must wait until its next turn to send the next packet.
- If the interface has no data to transmit, the interface ignores the select signals from the multiplexer. The multiplexer then switches to the next interface. Limiting transmissions to only one packet at a time improves response time when some users may be transferring large files and others may need access to system resources.

## Data Input

Data input occurs only when an incoming packet is recognized, based on the packet's destination node address. The following sequence of events occurs during data reception:

- The interface decodes the destination node address on all incoming packets. If the address does not match the interface node address switch setting, the packet is ignored.
- If the node address is recognized by the interface, the interface accepts the packet, strips off destination and control information, and prepares the data for transfer to the operating system or other destination level.
- The processed data is then transferred to the specified destination level for further action.

## Interface Operation

When the multiplexer activates RT (Receive Timing), the interface responds with data **only** if the interface has a packet ready to transmit. If there is at least one packet waiting for transmission, the interface synchronizes on the incoming RT signal which is also sent back out on TT (Terminal Transmit Timing). The interface then begins sending flag characters on the SD (Send Data) line, followed by the remainder of the SDLC frame after the CS (Clear-to-Send) signal is received from the multiplexer. When the frame is complete, the multiplexer disables CS and RT, causing the interface to place its output in an idle state.

Interaction of the interface with the computer is not as straight-forward, and is beyond the scope of this manual, as is the operation of the processor and other control circuitry on the interface. It is sufficient to explain that the node address switch is used by the microprocessor on the card to input the interface node address during power-up and after a hard **RESET**. The select code and hardware interrupt level switches control interaction between the interface and the computer's I/O circuitry.

# HP 98029A Resource Management Interface

## Theory of Operation

The HP 98029A Resource Management Interface performs essentially the identical function for an HP 9835A/B or an HP 9845B/C computer as the HP 98629 Resource Management Interface performs for HP 9000 Series 200 or Series 300 computers. Data transmission and reception are identical, and interaction with the multiplexer is also the same. The difference between the two interfaces lies in the interaction with the computer where they reside.

The interface consists of two printed circuit cards interconnected by two single-row connectors. The 98029-66502 board contains the Z-80 microprocessor, memory, datacomm SIO, and differential line drivers and receivers for the datacomm link to the multiplexer. The 98029-66501 contains interface circuitry between the Z-80 processor and the HP 9835/9845 computer I/O backplane. It includes a master clock oscillator, hardware register selection circuits, and interrupt and handshake logic.

Data is transferred to and from the HP 9835/9845 through the R4 registers, U6 and U7, one in each direction. Register contents are valid only if the flag is set. Register 5IN provides status and interface ID information; 5OUT is used to pass interface control information from the HP 9835/9845 to the interface.

Registers 5IN and 5OUT are interpreted as follows:

### R5IN:

15	14	13	12	11	10	9	8	7	6	5	4	3	2	1	0
x	x	x	x	1	0	0	1	IES	x	0	0	x	DBS	DA	DBE

x = not used    1 = always 1    0 = always 0

- Bit 0 (DBE) Data Buffer Enabled: When this bit is set and is ANDed with Bit 7, this bit indicates the data buffer can interrupt the mainframe when the data buffer has space available for another packet.
- Bit 1 (DA) Data Available: When this bit is set, the interface has a packet of information available for the mainframe.
- Bit 2 (DBS) Data Buffer Status: When this bit is set, it indicates the interface has space available for another outbound data packet.
- Bit 7 (IES) Interrupt Enable Status: When this bit is set, it indicates the interface can interrupt the mainframe when the prescribed conditions are met.

Bits 4 and 5 set to zero means the interface ID is contained in bits 11 through 8. All other bits in this register are not implemented.

**R5OUT:**

15	14	13	12	11	10	9	8	7	6	5	4	3	2	1	0
x	x	x	x	x	x	x	x	IEN	x	PR	x	x	x	DTE	DBE

x = not used

- Bit 0 (DBE) Data Buffer Empty: When this bit is set, it enables (clear disables) interrupt when the data buffer has space available for another outbound data packet.
- Bit 1 (BTE) Diagnostic Test Enable: When this bit is set, it interrupts the Z-80 CPU and causes the Z-80 CPU to execute a diagnostic text. This bit is used for factory and system diagnostic tests.
- Bit 5 (PR) Programmable Reset: When this bit is set, it causes an interface hardware reset. This bit is automatically cleared during reset.
- Bit 1 (IEN) Interrupt Enable: When this bit is set, it enables interruption of the mainframe by the interface when an incoming data packet has arrived, or when the outbound data buffer has space available for another packet (if Bit 0 is also set).

# HP 97061 Cable

The HP 97061 cable is used to connect multiplexers to resource management interfaces. The cable consists of six twisted-pair shielded two-wire cables enclosed within an outer shield that is covered with a plastic protective jacket. Each pair has a nominal balanced transmission line impedance of approximately 100 ohms. One end has a 50-pin connector that mates with the interface. The 15-pin connector on the other end mates with any one of the connectors on the multiplexer.

The following schematic diagram shows the pin connections and internal wiring of the cable for troubleshooting purposes. The molded connectors attached to the cables are not field repairable. Connector replacement requires the correct connector and the necessary tools to rewire the new connector, and is not generally recommended. Grounds must be correctly wired to ensure proper RFI performance and maintain noise immunity.

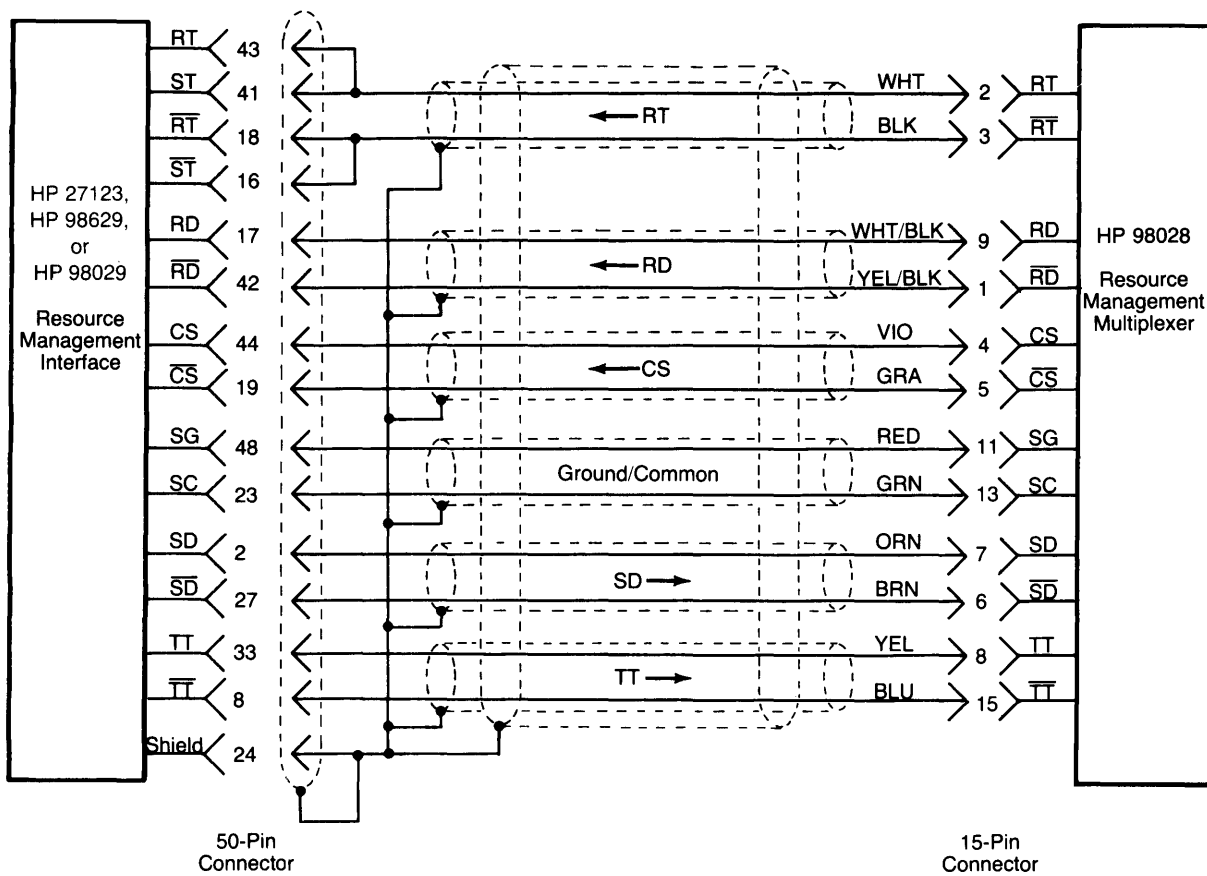

HP 97061 Cable Schematic Diagram





# Index

---

## a

AC line frequency .....	28
AM7960 transceiver .....	94, 95
anti-static bag .....	14, 19, 22, 64
anti-static grounding devices .....	14, 64
AUDIO receptacles .....	35

## b

barrel connectors .....	58, 59, 70
BASIC operating system .....	82
BNC T connectors .....	6, 11, 57, -60, 69-71, 72, 93
broadcast .....	113, 116
bus .....	3, 42, 47, 49
bus address .....	42, 43, 48-51, 99
Bus addresses:	
plotters .....	55
printers .....	48
servers .....	42
bus connections .....	40
bus fashion .....	93
bus length limitations .....	40, 41, 46

## c

Ciper protocol .....	49
Clear-to-Send line .....	114-116
clearances .....	82
clock signals .....	115
Coax:	
access state machine .....	95
adapter .....	1-3, 6, 13-17, 32, 58-60, 68-71, 75, 76, 93
connections .....	58-70, 76
connector .....	71
interface .....	3, 59, 60, 68-71, 97
network .....	3, 4, 6, 7, 10, 57-59, 63, 66, 68, 72, 75-78, 81, 103
transceiver .....	95, 97
coaxial cable .....	6, 11, 13, 57, 93
control blocks .....	96
controller .....	42
CS line .....	114-116
CTS line .....	95

## d

daisy chain pattern .....	44, 47, 50, 56
Data:	
blocks .....	96
communication .....	79
packets .....	96, 113
settling time .....	41
transmissions .....	93, 115
datacomm SIO .....	117
DC-to-DC converter .....	113
dedicated circuits .....	11
DIO interface .....	96
disc drives .....	5
dual-controller .....	42

## e

electromagnetic interference .....	8, 9, 11
electrostatic discharge .....	14, 64
equipment layout .....	8
Examples:	
Multiple Servers and Multiple Discs .....	87-92
Multiple Servers and Multiple Networks .....	106-111
Simple SRM System .....	83-86
extra RAM memory .....	19

## f

flag characters .....	95, 114
flip switches .....	18, 65

## g

graceful system shutdown .....	25
grounding wire .....	58

## h

handling interfaces .....	14, 64
handshaking .....	94, 114, 115
hardware .....	79, 81
hardware terminology .....	3
high data transfer rates .....	41
high-speed HP-IB signal exchanges .....	48
HP-IB:	
bus .....	42, 47
cable .....	8, 40, 42, 44-48
interface .....	29, 30, 33, 40, 44, 46, 47, 50, 56
port .....	24, 44-47

HP-UX operating system .....	82
HP Vectra Workstation .....	78, 81, 82
HP 27123A Resource Management Interface .....	3, 6, 72, 93, 105, 112
HP 35731B Video Monitor .....	36, 38
HP 50961 Resource Management Coax Adapter .....	
.....	1, 3, 6, 13-17, 32, 58, 59, 66, 68, 75, 79, 93-96, 115
HP 50962A SRM Coax Interface .....	1, 3, 6, 13, 17, 58, 59, 66, 79, 82, 96-98
HP 82913A Video Monitor .....	34-36
HP 97601 Cables .....	1, 79, 103, 105, 119
HP 98028A Resource Management Multiplexer .....	1, 66, 79, 103, 105, 112-115
HP 98029A Resource Management Interface .....	1, 79, 117, 118
HP 98169A Operating System Software .....	82
HP 98546-66571 Composite Video Interface .....	27, 28
HP 98629 Resource Management Interface .....	
.....	1, 3, 13-17, 58, 59, 66, 68, 79, 82, 93, 96, 105, 115-117
HP 9888A Bus Expander .....	19, 105

## i

installation planning .....	8
insulators .....	58, 60, 71, 72
interface configuration switches .....	17, 65
interrupt level .....	17, 67, 97
I/O interfaces .....	6, 13, 18-23, 81, 99

## k

### Keyboards:

HP 46020A HP-HIL .....	2, 17, 29, 32, 33
HP 46021A HP-HIL .....	2, 17, 29, 32, 33

## l

line drivers .....	94, 113
line impedances .....	115
line voltage .....	16
low-speed HP-IB devices .....	47, 49

## m

mass storage devices .....	39, 40, 42, 44, 45
Mass Storage Devices:	
HP 35401 .....	40, 44
HP 7907 .....	40, 42
HP 7908P/R .....	40, 42
HP 7911P/R .....	40, 42
HP 7912P/R .....	40, 42
HP 7914P/R .....	40, 42
HP 7935 .....	40, 42
HP 7936 .....	40, 43
HP 7937 .....	40, 43

HP 7941A	40, 43
HP 7942A	40, 43
HP 7946A	40, 43
HP 7957	40, 43
HP 7958	40, 43
HP 7959B	40, 43
HP 9122D/S	40, 43
HP 9133H/L option 001	40, 43
HP 9134H/L option 001	40, 43
HP 9144A	40, 43
HP 9145A	40, 43
HP 9153B	40, 44
maximum system configuration	19
maximum system performance	19
Memory Boards:	
HP 98256A 256-Kbyte RAM	2, 22, 23
HP 98257A 1Mbyte RAM	2, 19–21
message packets	95–97, 115, 116
multiple servers	61
Multiplexer:	
analog circuits	115
control circuit	113
data input	116
data transmission	116
handshaking	114, 115
interface operation	116
line drivers	114
network	1, 3, 4, 6, 10, 63, 66, 72, 103–120
port isolation	113
power supplies	113
receivers	113
switching	113

## n

Network:	
configuration compatibilities	105
configuration differences	105
grounding	12
management control hardware	97
performance	61
system	6, 57
node addresses	9, 10, 17, 30–32, 66, 68, 73–75, 97, 99, 115, 116

## o

on-line backup	19
opto-isolators	113, 115
outbound data	96

## p

PAL .....	95
Pascal operating system .....	82
peripheral installation .....	39-56
peripherals .....	1, 3, 5, 39
Physical Arrangement of:	
mass storage devices .....	41
plotters .....	47
printers .....	47, 48
plotters .....	5, 39, 46
Plotters:	
HP 7440 .....	46, 55
HP 7550A .....	46, 55
HP 7570 .....	46, 55
HP 7580A/B .....	46, 55
HP 7585A/B .....	46, 55
HP 7586B .....	46, 55
HP 7595 .....	46, 56
HP 7596 .....	46, 56
HP 9872B/C/S/T .....	46, 55
port isolation .....	113
ports .....	6, 103, 105, 113
Power:	
requirements .....	82
supplies .....	113
printers .....	5, 39, 46
Printers:	
HP 2563A .....	46, 48
HP 2608A/S .....	46, 49
HP 2631B/G .....	46, 49
HP 2932A .....	46, 50
HP 2933A .....	46, 50
HP 2934A .....	46, 50
HP 9876A .....	46, 50
Serial .....	46, 51

## r

RAM switches .....	20, 21, 22
RD line .....	115
Receive Data line .....	115
Receive Time line .....	114-116
receivers .....	94, 113
receiving adapter .....	94
registers .....	117, 118
repair .....	79
reset .....	95
Resource Management:	
server .....	3
system .....	3

rocker switches .....	18, 65
RS-232 .....	51, 52, 53, 55
RS-422 .....	94, 113
RT line .....	114-116
RxC lines .....	95
RxD lines .....	95

## S

SD line .....	114, 116
SDLC .....	95, 113-116
select codes .....	9, 17, 31, 67, 68, 73, 97, 99
Send Data line .....	114, 116
serial I/O communications chip .....	96, 97
Serial:	
Cables .....	51, 53
Port .....	52
Printers .....	46, 51
Server:	
backplane .....	5, 6, 21, 37, 46
communication .....	13
installation .....	13-38
Server Interfaces:	
HP 50962A SRM Coax Interface .....	30, 31
HP 98204A Composite Video .....	26
Human Interface/HP-IB .....	29
Server Types:	
HP 27123A .....	3
HP 50960A .....	5, 9, 13-18, 29, 57, 68, 81, 105
HP 9000 Model 220 (9920) .....	5, 13, 24
HP 9000 Model 226 (9826A) .....	5, 13, 24
HP 98029A .....	3
HP 98629 .....	3
service .....	79
Shared:	
disc file .....	5
file system .....	4, 63
memory .....	96
peripherals .....	4, 5-8, 39, 46, 63, 79, 99
shielding .....	11, 40, 46
Signal:	
levels .....	95
reliability .....	41
Site Preparation Checklist .....	11
slider switches .....	18, 65
software .....	82
SRM:	
Backup/Restore Utility Rev. 3.0 .....	82
coax interface .....	4
components .....	2
Disc Check Utility Rev. 3.0 .....	82

Installation Utility Rev. 3.0 .....	82
interface .....	4
overview .....	1
server backplane .....	100
System Rev. 3.0 WITH Backup/Restore .....	82
System Rev. 3.0 WITHOUT Backup/Restore .....	82
star pattern .....	47, 50, 56
status registers .....	96
subunit address .....	42
supported hardware .....	81
switches .....	9, 18, 65
Synchronous Data Link Control .....	95, 113, 114, 116
System:	
resources .....	4
shutdown .....	25
software .....	82

## t

technical considerations .....	8
Terminal Transmit Timing .....	114, 116
terminators .....	13, 58–60, 70, 71, 77
time-shared access .....	95, 97
transmitting adapter .....	94
troubleshooting .....	79
TT line .....	114, 116

## u

unit load .....	47–49
-----------------	-------

## v

VIDEO IN receptacle .....	35, 37
Voltage Select:	
cylinder .....	16, 17
setting .....	16, 17
volume configuration setting .....	42

## w

weights .....	82
workstation installation .....	63–78
workstations .....	4, 5, 8, 79
Workstations:	
HP 9000 Series 200 .....	2, 66, 71, 82, 93, 103, 104, 117
HP 9000 Series 300 .....	2, 66, 71, 82, 93, 103, 104, 117
HP 9000 Series 500 .....	2, 72, 82, 93, 103, 104
HP 9835A/B .....	82, 104, 112, 117
HP 9845B/C .....	82, 104, 112, 117
HP Vectra .....	78, 81, 82

**X**

XON XOFF Handshaking ..... 51

**Z**

Z-80 microprocessor ..... 117, 118



**MANUAL COMMENT CARD**

Your comments and suggestions help us determine how well we meet your needs.

HP Part Number 98619-90023

E1289

**Shared Resource Management  
Hardware Installation Manual**

**Agree**

**Disagree**

The manual is well organized.

It is easy to find information in the manual.

The manual explains features well.

The manual contains enough examples.

The examples are appropriate for my needs.

fold ---

The manual covers enough topics.

Overall, the manual meets my expectations.

**You have used this product:**

Less than 1 week

Less than 1 year

More than 2 years

Less than 1 month

1 to 2 years

Please write additional comments, particularly if you disagree with a statement above. Use additional pages if you wish. The more specific your comments, the more useful they are to us.

**Comments:** \_\_\_\_\_

\_\_\_\_\_  
\_\_\_\_\_  
\_\_\_\_\_  
\_\_\_\_\_  
\_\_\_\_\_  
\_\_\_\_\_  
\_\_\_\_\_  
\_\_\_\_\_  
\_\_\_\_\_  
\_\_\_\_\_  
\_\_\_\_\_  
\_\_\_\_\_

fold ---

Name: \_\_\_\_\_

Job Title: \_\_\_\_\_

Company: \_\_\_\_\_

Address: \_\_\_\_\_

Check here if you wish a reply.



NO POSTAGE  
NECESSARY  
IF MAILED  
IN THE  
UNITED STATES

**BUSINESS REPLY MAIL**  
FIRST CLASS      PERMIT NO. 37      LOVELAND, COLORADO

POSTAGE WILL BE PAID BY ADDRESSEE

**Hewlett-Packard Company  
Colorado Networks Division  
3404 East Harmony Road  
Fort Collins, Colorado 80525-9988**

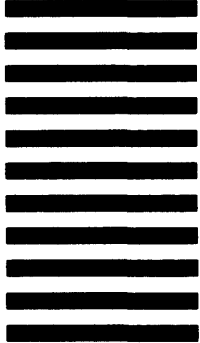





**HP Part Number**  
**98619-90023**  
Printed in U.S.A. E1289



**98619-90023**  
For Internal Use Only

# Shared Resource Management System Manager's Guide

HP 9000 Computers

HP Part Number 98619-90033



**Hewlett-Packard Company**

3404 East Harmony Road, Fort Collins, Colorado 80525

## NOTICE

The information contained in this document is subject to change without notice.

HEWLETT-PACKARD MAKES NO WARRANTY OF ANY KIND WITH REGARD TO THIS MANUAL, INCLUDING, BUT NOT LIMITED TO, THE IMPLIED WARRANTIES OF MERCHANTABILITY AND FITNESS FOR A PARTICULAR PURPOSE. Hewlett-Packard shall not be liable for errors contained herein or direct, indirect, special, incidental or consequential damages in connection with the furnishing, performance, or use of this material.

## WARRANTY

A copy of the specific warranty terms applicable to your Hewlett-Packard product and replacement parts can be obtained from your local Sales and Service Office.

Copyright © Hewlett-Packard Company 1989

This document contains information which is protected by copyright. All rights are reserved. Reproduction, adaptation, or translation without prior written permission is prohibited, except as allowed under the copyright laws.

### Restricted Rights Legend

Use, duplication or disclosure by the U.S. Government Department of Defense is subject to restrictions as set forth in paragraph (b)(3)(ii) of the Rights in Technical Data and Software clause in FAR 52.227-7013.

Use of this manual and flexible disc(s) or tape cartridge(s) supplied for this pack is restricted to this product only. Additional copies of the programs can be made for security and back-up purposes only. Resale of the programs in their present form or with alterations, is expressly prohibited.

# Printing History

---

New editions of this manual will incorporate all material updated since the previous edition. Update packages may be issued between editions and contain replacement and additional pages to be merged into the manual by the user. Each updated page will be indicated by a revision date at the bottom of the page. A vertical bar in the margin indicates the changes on each page. Note that pages which are rearranged due to changes on a previous page are not considered revised.

The manual printing date and part number indicate its current edition. The printing date changes when a new edition is printed. (Minor corrections and updates which are incorporated at reprint do not cause the date to change.) The manual part number changes when extensive technical changes are incorporated.

December 1989...Edition 1. This manual describes SRM systems of Revision 3.2 and earlier.  
This manual replaces 98619-90032.





# Table of Contents

---

## Introduction

About This Guide .....	2
When to Use This Guide.....	2
What Is in This Guide.....	2
Conventions Used in This Guide .....	3
SRM System Requirements.....	4
Hardware Requirements .....	4
Software Requirements .....	4
Conceptual Overview of the SRM System .....	5
SRM Operating System.....	5
SRM File System .....	5
Printer and Plotter Spooling .....	9
SRM Workstations .....	9
Additional References .....	10

## Part I: Routine System Management

### Chapter 1:

#### Customizing the System

Workstation Names .....	1-1
Assigning Workstation Names .....	1-1
Deleting Workstation Names .....	1-4
Viewing Workstation Names.....	1-4
Combining the Directory Structures of SRM Volumes.....	1-5
Some Cautions about Using the MOUNT Command .....	1-5
Mounting an SRM Volume .....	1-7
Unmounting an SRM Volume.....	1-9
Viewing Mounted Volumes .....	1-9

### Chapter 2:

#### Restarting and Stopping the Server

Overview .....	2-1
Restarting the Server .....	2-2
Stopping the Server .....	2-8

## Chapter 3:

### Managing Shared Peripherals

Overview .....	3-1
Increasing System Performance .....	3-2
Adding Memory .....	3-2
Reloading the SRM Operating System .....	3-2
Limiting Directory and Disc Capacity .....	3-2
Managing Mass Storage Devices .....	3-3
Protecting and Recovering Data .....	3-3
Using Removable Hard Disc Drives .....	3-3
Identifying Mass Storage Devices in Server Commands .....	3-4
Using Tape Drives on the Same Controller as a Disc .....	3-5
Managing an SRM Disc's Directory Structure .....	3-6
Determining the Percentage of Free Space on a Disc .....	3-7
Adding a Mass Storage Device to the System .....	3-8
Removing a Mass Storage Device from the System .....	3-11
About the SRM System Disc .....	3-12
Managing Printers and Plotters .....	3-14
Identifying Printers and Plotters in Server Commands .....	3-14
Printing Information from the Server's Display .....	3-15
Stopping the Printing or Plotting of a File .....	3-16
Adding an HP-IB Printer or Plotter to the System .....	3-18
Adding a Serial Printer or Plotter to the System .....	3-20
Configuring a Serial Printer on the System .....	3-22
Removing a Printer or Plotter from the System .....	3-25
Viewing Spooler Information .....	3-26
Sending Files from a Workstation to a Printer or Plotter .....	3-27
Printer Environments and Priority Spooling .....	3-27

## Chapter 4:

### Backup Design and Media Management

Overview .....	4-1
Backup Features, Capabilities, and Limitations .....	4-2
Selective Backup .....	4-2
One Disc per Backup .....	4-4
Back Up on Demand or Automatically on a Regular Schedule .....	4-4
Backup Status Checks .....	4-5
Backup Media Features .....	4-5
Terms and Concepts .....	4-6
Designing a Backup Strategy .....	4-8
Evaluating the Files on the System .....	4-8
Other Considerations .....	4-9
An Example Backup Strategy .....	4-9
Managing Backup Media .....	4-11
Example Media Retention and Reuse Plans .....	4-14

## Chapter 5:

### Performing a Backup

Overview .....	5-1
Starting the Backup/Restore Utility .....	5-2
Specifying a Backup's Scope .....	5-7
Preparing for a Backup's Execution .....	5-13
Manually Starting a Backup .....	5-14
Scheduling a Backup to Start Automatically .....	5-18
While a Backup Is in Progress .....	5-23
Using the SRM System .....	5-23
Checking a Backup's Status .....	5-24
Stopping a Backup in Progress .....	5-24
Continuing a Paused Backup .....	5-25
If a Scheduled Backup Overlaps with One in Progress .....	5-25
After a Backup Has Completed .....	5-26
If You Performed the Backup with the Backup/Restore Utility .....	5-26
Check the Log File for Backup Errors .....	5-26
Label Backup Media and Store Them in a Safe Place .....	5-27
Viewing and/or Changing the Current Backup Setup .....	5-28
Viewing the Values That Define the Scope of a Backup .....	5-28
Viewing Scheduled Backup Information .....	5-30
Changing the Contents of a Backup File .....	5-31
Performing Other Operations Regarding Backup Files .....	5-35
Changing a Backup's Automatic Startup Schedule .....	5-35

## Chapter 6:

### Restoring from Backups

Overview .....	6-1
Restore Features, Capabilities, and Limitations .....	6-1
Selective Restore .....	6-2
What to Expect from a Restore .....	6-3
Treatment of Backup Media .....	6-4
Restoring a Disc's Entire File System .....	6-5
If a Restore Includes the SYSTEMS Directory .....	6-6
Performing a Restore .....	6-7
While a Restore Is in Progress .....	6-18
Using the SRM System .....	6-18
Checking a Restore's Status .....	6-19
Stopping a Restore in Progress .....	6-19
Continuing a Paused Restore .....	6-19
After You Have Performed a Restore .....	6-20
If You Performed the Restore with the Backup/Restore Utility .....	6-20
Check the Log File for Restore Errors .....	6-20

## Part II: Troubleshooting

### Chapter 7:

#### Diagnosing and Correcting a Corrupt Disc

Overview .....	7-1
Checking a Disc for Unreadable Areas .....	7-3
Checking and Repairing a Disc's File System .....	7-5
Starting the Disc Check Utility .....	7-5
Checking a Disc's File System .....	7-9
Repairing a Disc's File System .....	7-13
Disc Check Utility Messages .....	7-17
Message List .....	7-17

### Chapter 8:

#### Fixing Common Printer and Plotter Problems

Overview .....	8-1
Out of Paper Condition .....	8-1
Paper Jam .....	8-1
Offline .....	8-2
Workstation's File Not Printing or Plotting .....	8-2
Determining If a Workstation User's File Is Open .....	8-2
Closing a Workstation User's File .....	8-4
"Dump Alpha" or "Print All" Keyboard Function Problem .....	8-5
SPOOLER or UNITS Command Malfunction .....	8-5
Printer or Plotter Device Error .....	8-6

### Chapter 9:

#### Diagnostic Flowcharts

Overview .....	9-1
Flowchart 1 .....	9-4
Flowchart 2 .....	9-6
Flowchart 3 .....	9-8
Flowchart 4 .....	9-9
Flowchart 5 .....	9-11
Flowchart 6 .....	9-12
Flowchart 7 .....	9-13
Flowchart 8 for Coax Link Configurations .....	9-15
Flowchart 9.1: Problem at the Server's HP 98629/50961 Pair .....	9-17
Flowchart 9.2: Problem at the Server's HP 50962A Interface .....	9-19
Flowchart 10: Problem in the Cable or at a Remote Node .....	9-21
Flowchart 11: Problem with the Link .....	9-24

## Chapter 10:

### SRM Server Messages

System Errors .....	10-1
Backup/Restore Errors .....	10-1
Device Errors .....	10-1
HP 98629/50962A Interface Card Errors .....	10-2
HP-IB/Disc Interface Card Errors .....	10-2
Printer/Plotter Errors .....	10-2
System Management Errors .....	10-2
Message List .....	10-2

## Part III: Reference

### Appendix A:

#### Server Keyboard Functions and Commands

Special Keyboard Functions .....	A-1
Clear I/O .....	A-1
Clear Screen .....	A-2
Dump Alpha .....	A-2
Print All .....	A-2
Recall .....	A-2
Enable/Disable User Request Trace .....	A-3
Server Command Syntax Conventions .....	A-4
devaddress .....	A-4
directory specifier .....	A-5
root password .....	A-5
userid .....	A-6
volspec .....	A-6
Server Commands .....	A-7
BACKUP .....	A-7
FILES .....	A-8
HEADER .....	A-10
HELP .....	A-11
INITIALIZE .....	A-12
INTERFACES .....	A-14
MOUNT .....	A-15
NAME .....	A-16
NODES .....	A-17
READ_CONFIGURATION .....	A-18
REMOVE_USER .....	A-19
RENAME .....	A-20
RESET .....	A-20
RESTORE .....	A-21
SAVE_CONFIGURATION .....	A-22
SPOOLER .....	A-23
SYSTEM .....	A-25
TIME .....	A-26
TRACE .....	A-27
UNITS .....	A-28

UNMOUNT .....	A-30
USERS .....	A-30
VERIFY .....	A-31
VOLUMES .....	A-33
? .....	A-34
* .....	A-35

**Appendix B:**

**Restoring from Pre-3.0 SRM Backups**

.....	B-1
-------	-----

**Appendix C:**

**2608A Driver Supported Escape Sequences**

hskip 2em. ....	C-1
-----------------	-----

**Appendix D:**

**Operating System Enhancements**

Introduction .....	D-1
SRM 1.0 vs. SRM 2.0 .....	D-1
SRM 2.0 vs. SRM 2.1 .....	D-2
SRM 2.1 vs. SRM 2.2 .....	D-2
SRM 2.2 vs. SRM 3.0 .....	D-3
SRM 3.0 vs. SRM 3.1 .....	D-4
SRM 3.1 vs. SRM 3.2 .....	D-5

**Appendix E:**

**Glossary**

.....	E-1
-------	-----

**Index**

.....	1
-------	---

# Introduction

---

The Shared Resource Management (SRM) system allows sharing of files and peripheral devices within a network of workstations.

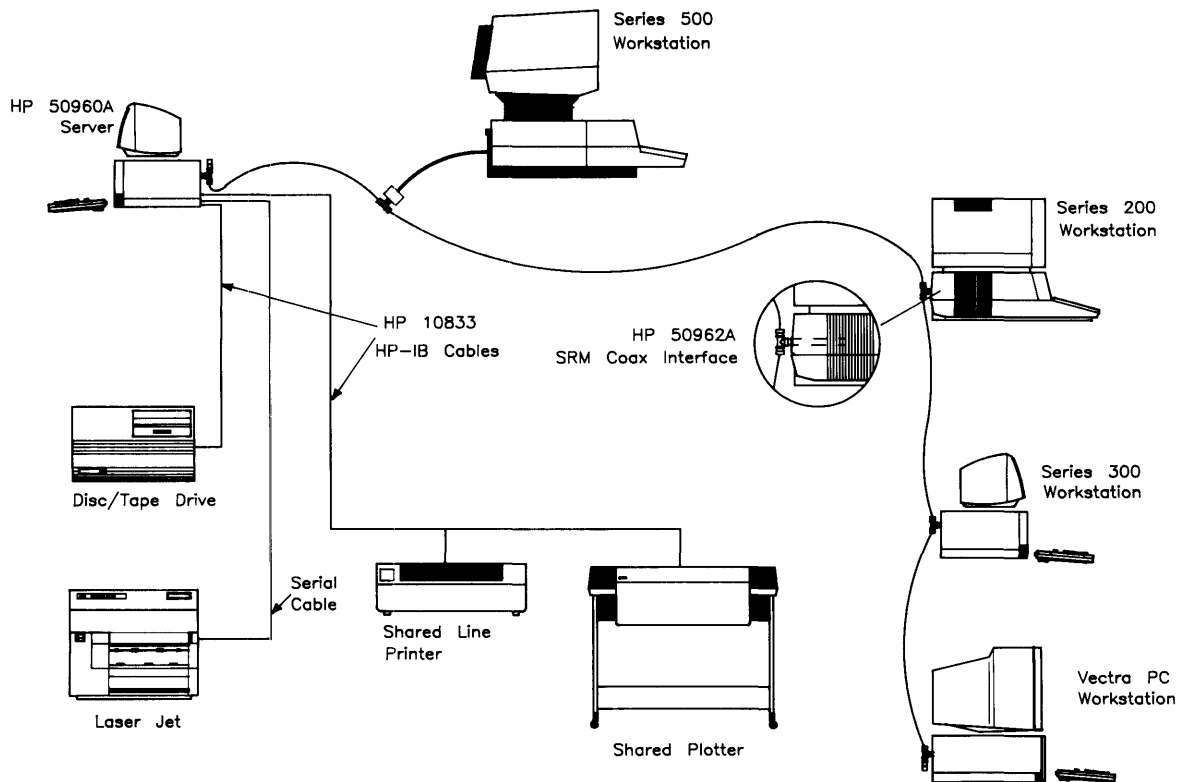

**Example of a Shared Resource Management System Using the Coax Network**

---

## About This Guide

The SRM system manager (the person who sets up, maintains and troubleshoots the SRM system) should read this guide.

## When to Use This Guide

Use this guide **AFTER**:

- you have planned your SRM system and prepared its site using the *Shared Resource Management System Planning Guide*,
- you have installed the SRM system hardware using the *Shared Resource Management Hardware Installation Manual*, and
- you have installed the SRM system software for an SRM server and its workstations using the *Shared Resource Management Software Installation Manual*.

## What Is in This Guide

This is **NOT** a workstation manual and does not explain the user commands or user interface for workstations connected to the SRM system.

The following is a summary of what this guide covers:

This **Introduction** gives system requirements, a conceptual overview of the SRM system, and additional references.

### Part I: Routine System Management

*Use this part of the guide to learn how to perform routine SRM system management and to become more familiar with how the system works.*

**Chapter 1** describes how to customize your system by assigning names to workstations and by combining the directory structures of SRM discs.

**Chapter 2** explains how to restart and stop an SRM server (or bring up the system and bring down the system).

**Chapter 3** discusses how to manage the system's shared peripherals (mass storage devices, printers, and plotters) for maximum performance, efficiency, and security.

**Chapter 4** gives suggestions for designing a system backup strategy and media management scheme.

**Chapter 5** covers how to perform a backup and change the system's current backup setup.

**Chapter 6** covers how to restore backed up directories and files to reconstruct an entire file system or only part of it.



## **Part II: Troubleshooting**

*Use this part of the guide when something goes wrong with the SRM system, and you need help correcting the problem.*

**Chapter 7** explains how to use the Disc Check Utility to diagnose and correct a disc's directory and file structure in the event of accidental disc corruption.

**Chapter 8** explains how to fix common spooled device (printer and plotter) problems.

**Chapter 9** contains diagnostic flowcharts for isolating and repairing system faults.

**Chapter 10** lists SRM server messages and briefly explains each message.

## **Part III: Reference**

*This part of the guide contains reference information on miscellaneous topics.*

**Appendix A** is a summary of server keyboard functions and commands.

**Appendix B** describes how to restore files from SRM 2.2 and earlier backups.

**Appendix C** contains the escape sequences supported by the 2608A printer.

**Appendix D** gives the operating system enhancements for SRM 2.0, SRM 2.1, SRM 2.2, SRM 3.0, SRM 3.1, and 3.2.

**Appendix E** is a glossary of SRM terminology.

---

## **Conventions Used in This Guide**

Document titles and disc labels are in *italics*.

References to chapter and section titles are in quotation marks (“ ”).

Text appearing on a server's or workstation's display (whether it is generated by software or by your typing at the keyboard) is shown in **computer font**.

Keycaps, such as Return, are boxed. When shown after a line of **computer font**, they indicate the key or keys to press after typing the preceding text.

Where this manual shows two different keycaps in a row, the first keycap is for an HP 46020A or HP 46021A keyboard. The second keycap is the equivalent key for an HP 98203A or HP 98203B keyboard.

Procedures are in an indented, step-by-step paragraph format. When a procedure step requires supporting information (such as syntax details, examples, or a multiple-choice decision), this information appears below the step.

Troubleshooting hints are in framed boxes.

---

# SRM System Requirements

Listed below are the minimum requirements for an SRM system. The hardware components are covered in more detail in the *Shared Resource Management System Planning Guide* and the *Shared Resource Management Hardware Installation Manual*.

## Hardware Requirements

HP 50960A, HP 9000 Model 220 or Model 226 SRM server <sup>1</sup>	with <b>at least</b> 768 Kbytes of RAM memory for SRM system <b>with</b> on-line backup and restore, and serial printers or with <b>at least</b> 512 Kbytes of RAM memory for SRM system <b>without</b> on-line backup and restore, and serial printers
Keyboard and monitor and supporting interfaces	integrated for the Model 226
Two HP-IB ports	high-speed for mass storage devices, slower speed for printers and plotters high-speed built-in for HP 50960A slow-speed built-in for Model 226
DMA Controller	built-in for HP 50960A
SRM Coax Interface	for coax link configuration
Supported hard disc drive with tape drive	tape drive used for initial system installation and backup; see list of SRM supported tape drives in the <i>SRM System Planning Guide</i>

## Software Requirements

<i>SRM Systems &amp; Utilities</i> tape cartridge	volume name: SRM3_1 file names: SYSTEM_INS SYSTEM_BKP SYSTEM_DSK SRM_W_BKP SRM_WO_BKP
---	--

---

<sup>1</sup> The terms “server” and “controller” are often used interchangeably in this manual. They signify the same entity: the component of the SRM system that executes the SRM Operating System software and manages access to the shared resources.

---

## Conceptual Overview of the SRM System

The *Shared Resource Management System Planning Guide* and *Shared Resource Management Hardware Installation Manual* familiarize you with SRM system requirements and hardware configuration possibilities. This overview acquaints you with the operational features and capabilities of a Shared Resource Management system.

### SRM Operating System

An SRM server running the SRM Operating System has a very specialized set of capabilities. As a multi-user file system built on a multi-tasking operating system, the SRM Operating System handles all activities related to the operation and use of shared system resources.

The SRM Operating System's command set allows you, the SRM system manager to:

- set up and monitor the configuration of peripherals and workstations recognized by the system,
- control and monitor the operation and use of the system's shared peripherals, and
- preserve the system's integrity by performing system backups and restoring files when necessary.

Note that an SRM server is dedicated to resource management activities **only** and can **NOT** be used simultaneously as a user workstation.

### SRM File System

With an SRM system, multiple workstation users can use a mass storage device connected to a server for storing and retrieving their files. Each mass storage device connected to an SRM server is called a "volume." The SRM system handles one or more mass storage volumes, each one physically and logically distinct from the others. Each volume has a unique name, optional associated password, and a unique volume address.

With many users' files on the same shared mass storage device, workstation users can easily access one another's files. In addition, multiple workstation users can access the same file simultaneously.

Such sharing of mass storage devices and files could become chaotic if the SRM system did not provide some organization, protection, and control mechanisms for the file system.

## Hierarchical Structure

To help keep the file system organized, the SRM supports a hierarchical directory structure. Directories themselves may contain files or other directories. This keeps the file system uncluttered because separate groups of related files can be put in different directories. Related directories can be grouped together under a single directory with an appropriate, encompassing name. Two or more files may have the same name, as long as they are in different directories. A workstation user can even work with files in one directory without ever having to be aware of the files in other directories above, below, or at the same level as the current one.

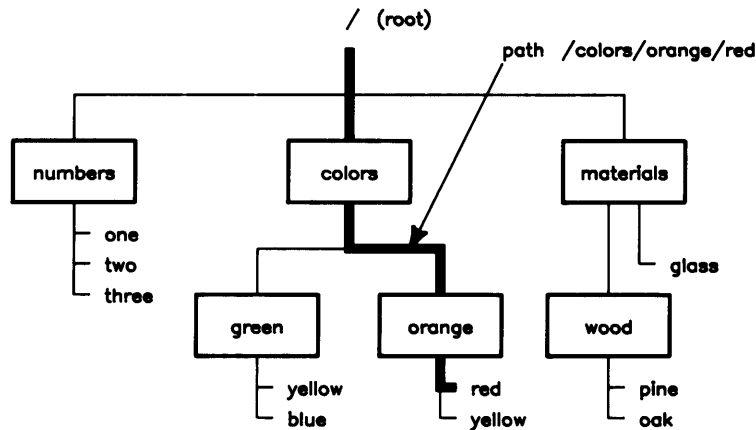

Example SRM Directory Structure

An SRM directory or file is identified by a combination of:

- the names of those directories you must follow in the hierarchy to reach that directory or file and
- the name of the directory or file itself.

This list of directory names, along with the name of the destination directory or file, is called a “path.” Names in a path are separated by slashes (/). A single or initial slash denotes the top (or “root”) of the hierarchical structure.

## Password Protection

To maintain security, access to an SRM volume, directory, or file may be restricted with a password. Only those who know the password assigned to a volume, directory or file may gain access to it.

Passwords are always enclosed in <> brackets to distinguish them from the volume, directory, and file names in a path.

The SRM system allows workstation users to further customize the type and extent of protection for their directories and files. The SRM system divides “access” into the types of operations that can be performed on a directory or file. These types of allowed operations are called “access capabilities.” For example, one access capability might be the ability to read a directory or file. Another might be the ability to write to a directory or file.

Different passwords may protect different sets of access capabilities for the same directory or file. In this way, a workstation user who knows a less powerful password assigned to a file would, for example, only be able to read that file. In contrast, a workstation user who knows a more powerful password assigned to the same file might be able to both read and write to that file.

### **Access Control**

When more than one workstation user has the ability to access a file at the same time, certain operations, if performed simultaneously, can cause unpredictable results. For example, two workstation users may simultaneously try to write different information to the same file. There is no way of telling which information will be written to the file.

The SRM system can protect files during critical operations by providing the ability to establish exclusive access to a file.

### **Extendable Directories and Files**

To use shared disc space most efficiently, the SRM system may store a file in pieces, called “extents.” This process is transparent and cannot be externally controlled. There are two advantages to this scheme:

- First, the system can use up free areas on the disc, even if their size and location vary. By filling free areas of the disc automatically, the system eliminates the need to pack the shared disc’s files.
- SRM directories and files can grow dynamically as data is entered into them. If additional entries added to a directory or additional data placed into a file would cause it to overflow its current space allocation, the system automatically allocates more space for the directory or file.

Directories and files are extended as long as there is sufficient unused disc space on the same volume. Excess data from a file will not be placed on any other disc (volume) on the SRM system.

## Duplicate Links to Files

Pascal Workstation System users and users of HP-UX systems with SRM File Access Utilities can create one or more alternate paths to an existing file. This is known as creating a “duplicate link” to a file.

With this capability, there is no need to have multiple copies of the same file taking up extra space on an SRM disc volume. Each user can access the same file through an “individualized” path—a meaningful path within the context of the user’s working directory structure.

Creating duplicate links to a file also saves time. Workstation users need not wait for the system to copy an entire file to a different path. The system can simply establish an additional path to an existing file.

The illustration below shows an example to clarify the concept of duplicate links to an SRM file:

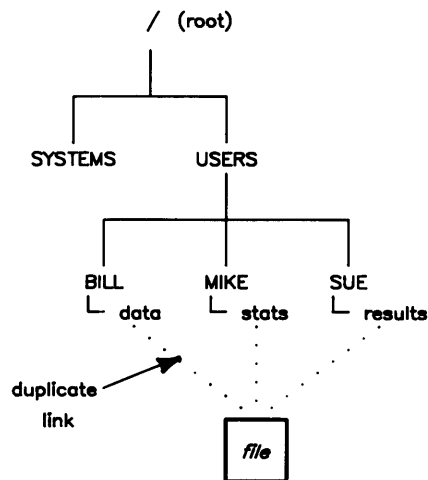

Example of Duplicate Links to an SRM File

## Printer and Plotter Spooling

The SRM Operating System provides printer and plotter spooling. Spooling allows multiple workstation users to send files to a shared printer or plotter whenever they want to, without waiting for the device to finish printing or plotting its current file.

Each SRM printer and/or plotter has a “spooler directory” associated with it. This directory temporarily holds files that workstation users place there for the printer or plotter to process.

If desired, a printer or plotter spooler directory can have a “priority” subdirectory. Files placed in the “priority” subdirectory are spooled before other files in the spooler directory. Priority spooling allows a rush file to pre-empt all other files in the spooler directory.

Spooler directories can also contain an “environments” subdirectory. The “environments” subdirectory contains files that define a printing environment (such as page orientation, font, etc.) and can be specified when sending a print file to a spooler directory. When specified, an environment file is sent to the printer ahead of the print file, setting the printing environment in which the print file is processed.

Once a file is placed in the appropriate spooler directory, a workstation is free to devote its processing power to tasks other than waiting for a printer or plotter to process the file sent to it.

Note that spooled devices on the SRM system can **NOT** send data **BACK** to a workstation. If you need to input data from the device to the workstation (such as in digitizing from a plotter), you must connect the device directly to the workstation.

Spooled devices on the SRM are discussed in more detail in the “Managing Shared Peripherals” chapter of this guide.

## SRM Workstations

SRM workstations have the advantage of being able to apply their independent processing power to a variety of shared resources.

Workstations running the BASIC Language System or the Pascal Workstation System have built-in access to an SRM server’s shared resources. Almost all of the statements or commands comprising each of these systems may be directly applied to directories and files on an SRM disc volume. Workstation users can even “boot” (start up) a BASIC Language or Pascal Workstation System that is stored on an SRM disc.

In contrast, the SRM File Access Utilities for HP-UX systems give HP-UX users a limited subset of special commands for common SRM file management operations. However, HP-UX users can transfer a file from an SRM disc to an HP-UX system disc (and vice-versa) and then work with the file using a multitude of HP-UX commands and applications.

No workstation on an SRM system can pass information directly to another workstation. To pass information from one workstation to another, one workstation must place the information in a shared file on an SRM disc. The other workstation can then access the file to get the information in it.